

Self-Regulating Parallel Trace Heaters

eltherm® 

Content

From Process to Product The eltherm Story	4
From A to Z Your One-Stop-Shop	6
Self-Regulating Parallel Trace Heaters	8
Selection Guide Low Temperature	10
Selection Guide Medium Temperature	12
Selection Guide High Temperature	13
Datasheets Self-Regulating Trace Heaters	14
Accessories Self-Regulating Trace Heater System	36
Applications Self-Regulating Trace Heater System	44
Design Guide Trace Heater System	46
Questionnaire for Electrical Heat Tracing Systems	48
At Your Service eltherm globally	50

„Understanding the application and finding the most efficient, reliable solution is our daily challenge“



Our specialists for applications with Self-Regulating Parallel Trace Heaters: Benjamin Knuff, Michelle Schmid and Mohamed Sellami.



eltherm in Burbach, Germany

- 1 Production facility I
- 2 Administration, application engineering
- 3 R&D, international sales, eltherm Academy
- 4 Production facility II



From Process to Product

The eltherm Story

Founded in 1991 in Burbach, Germany, eltherm has developed into a global engineering solution provider with own production facilities and a one-stop-shop for electrical heat tracing products and systems. The company has attained worldwide recognition as a turn-key partner for engineering, design, installation and commissioning of electrical heat tracing for complex industrial plants and facilities.

With its own comprehensive production facilities for all types of heating cables and accessories eltherm has built up the engineering expertise to become one of the leading manufacturers of electrical heat tracing systems in the world.

Besides frost protection and temperature maintenance applications up to 900 °C, eltherm is the competent partner for complete system solutions like heating whole chemical or other industrial plants. eltherm proved its potential and expertise in different industries such as oil and gas, power plant, construction, automotive and food.

› Portfolio Focus

We provide a comprehensive range of electrical heat tracing products, systems and solutions from A to Z. Your One-Stop-Shop.

› Customer Focus

Our focus on the benefits to our clients sets us apart from competitors. We understand and solve our clients' needs with technological passion.

› Technical Focus

We specialise in electrical heat tracing. That is our core competence and inspiration.

› Global Focus

We are a global engineering company with our own production facilities, serving international markets and projects from 14 locations on 5 continents – and with a staff force of 270.



From A to Z Your One-Stop-Shop

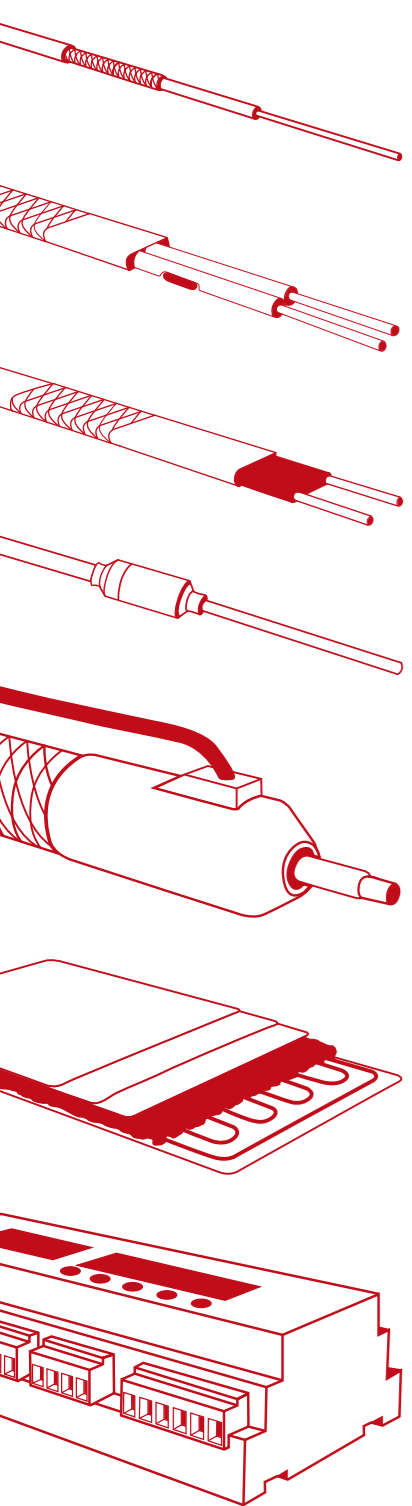

› Series Resistance Trace Heaters

for freeze prevention and process temperatures in industrial plants and facilities. Applications up to 900 °C.

› Parallel Resistance Trace Heaters

Parallel trace heaters with constant wattage output and a single end power input. For applications in hazardous and non-hazardous locations.

› Self-Regulating Parallel Trace Heaters

for freeze prevention and temperature maintenance in industry and building & construction. Applications up to 250 °C.

› Mineral-Insulated Trace Heaters

exclusively manufactured and finished from Alloy 825 or high-quality stainless steel. The unique "Clean Laser Seal" Technology (CLS) guarantees a homogenous, 100% stable system and reliable function up to 700 °C.

› Heated Analytic, Pressure and Loading Systems

for reliable and safe transport of pressurised or non-pressurised fluids and gases without temperature loss, up to 450 °C.

› Heating Mats and Jackets

custom-engineered and tailor-made, for heating valves, pumps, drums, barrels, hobbicks and flange covers, up to 900 °C.

› Power and Control Panels

including temperature sensors, display and operating devices, monitoring and controls plus accessories for reliable, safe functioning.

› Accessories

for safe and effective assembly and operation of complete heat tracing systems in facilities from small to large.

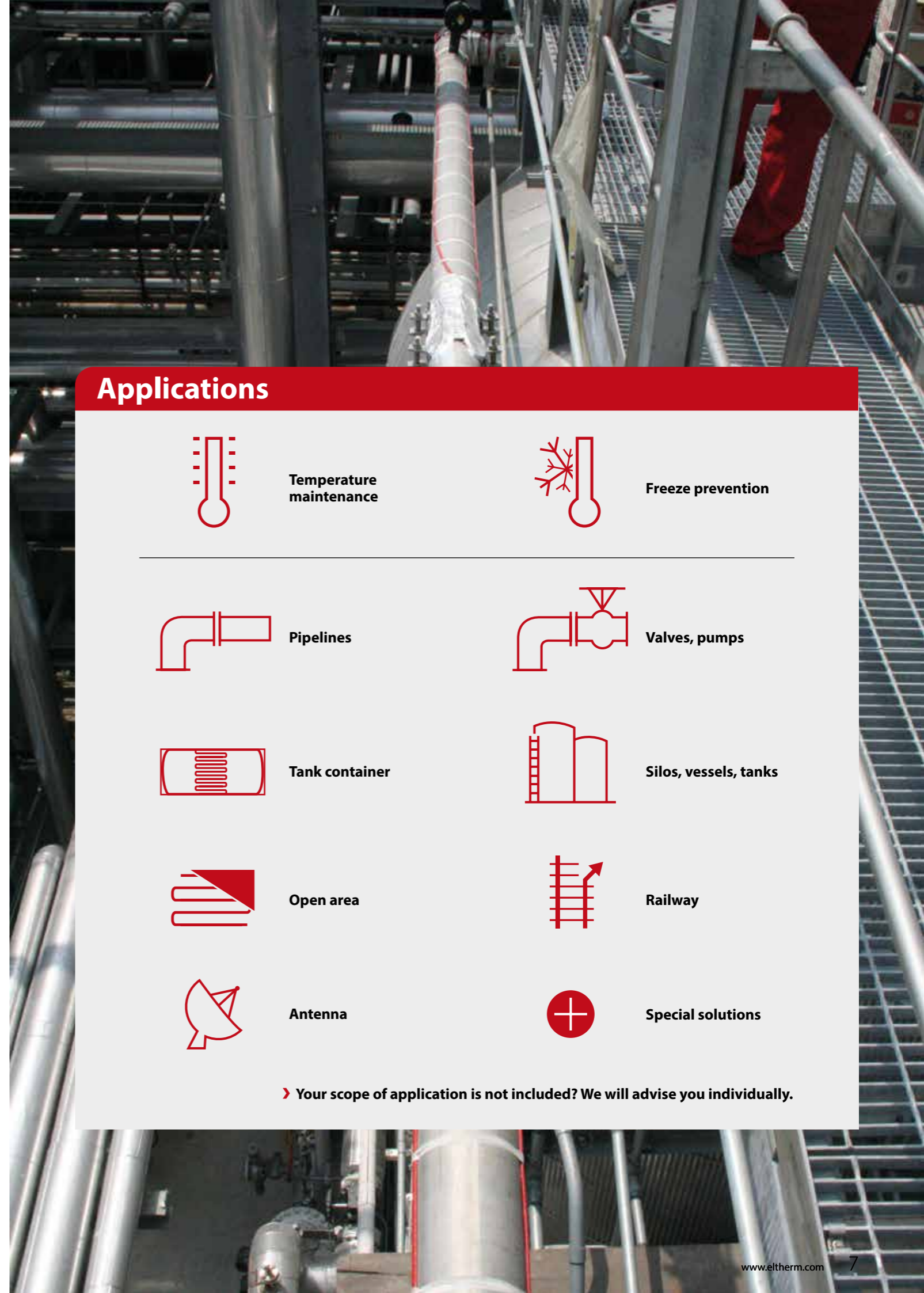

Applications



Temperature maintenance



Freeze prevention



Pipelines

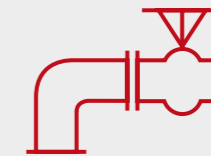

Valves, pumps

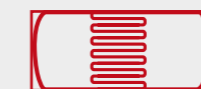

Tank container



Silos, vessels, tanks



Open area



Railway



Antenna



Special solutions

› Your scope of application is not included? We will advise you individually.

At a Glance

Benefits

- › Self-regulating with adaptable output
- › Various temperature ranges
- › Demand-orientated output grading
- › High chemical resistance
- › No temperature limitation required (Ex-area)
- › Easy to install
- › Can be cut to length off the roll
- › Fast connection with El-Clic

Design

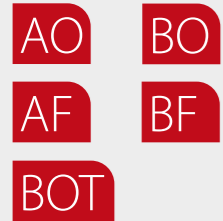

Approvals



- › Approved for USA / Canada

Self-Regulating Parallel Trace Heaters

Self-regulating trace heaters consist of two parallel bus wires embedded in a heating matrix doped with carbon particles. When the temperature rises in operation, molecular expansion increases the distance between the carbon particles. The resistance increases and output drops. When temperatures fall, this process is reversed and output increases. This physical property means that the heater will never overheat, can be assembled crosswise and can be operated without a temperature controller. Moreover, selected ELSR heating cables are approved for use in hazardous areas.

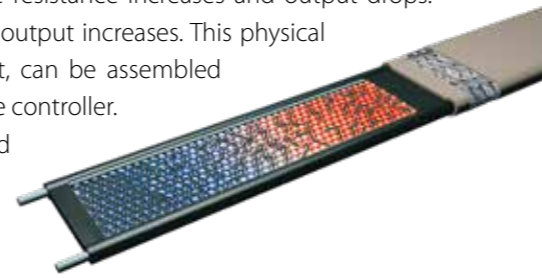

Application

The ELSR (eltherm-self-regulating) trace heater is used for freeze prevention and temperature maintenance on vessels, pipes, valves, etc. It may be immersed in fluids. For use in aggressive environments (e.g. in chemical or petrochemical industry), the trace heater is coated with a special chemically resistant outer jacket (fluoropolymer), option "BOT".

Design

A wide selection of self-regulating heater designs to handle almost any application, including service in harsh conditions and corrosive environments.

- AO** Aluminium foil with a thermoplastic outer jacket. Trace heater for all low-temperature and medium-temperature applications, particularly easy to assemble.
- BO** Protective braid with a thermoplastic outer jacket. Trace heater with protective tin-plated copper braid for all low-temperature and medium-temperature applications.
- BOT** Protective braid with fluoropolymer outer jacket (Teflon). Trace heaters with fluoropolymer outer jacket for use in aggressive chemical, oil and fuel environments. A detailed list of chemical resistances is available online.
- AF** Aluminium foil and outer jacket approved for food and potable water. Special trace heaters designed for use inside potable water lines in Freeze prevention (-M) applications.
- BF** Protective braid and outer jacket approved for food and potable water. Special trace heaters with robust protective braid for water and drinking water lines.
 - › ELSR-N...1... = Nominal voltage 110 V
 - › ELSR-N...2... = Nominal voltage 230 V

We also offer trace heaters with braid only, without outer jacket, upon request.

Checklist

The Self-Regulating Trace Heating System

- | | |
|--------------------------------|---|
| A Trace Heater | F Fasteners and Self-adhesive Tapes, Foils |
| B Power Connection Kit | G Insulation Bushing |
| C End Termination Kit | H Warning Sign |
| D Junction Box | I Temperature Controller |
| E Pipe Mounting Bracket | J Temperature Sensor |

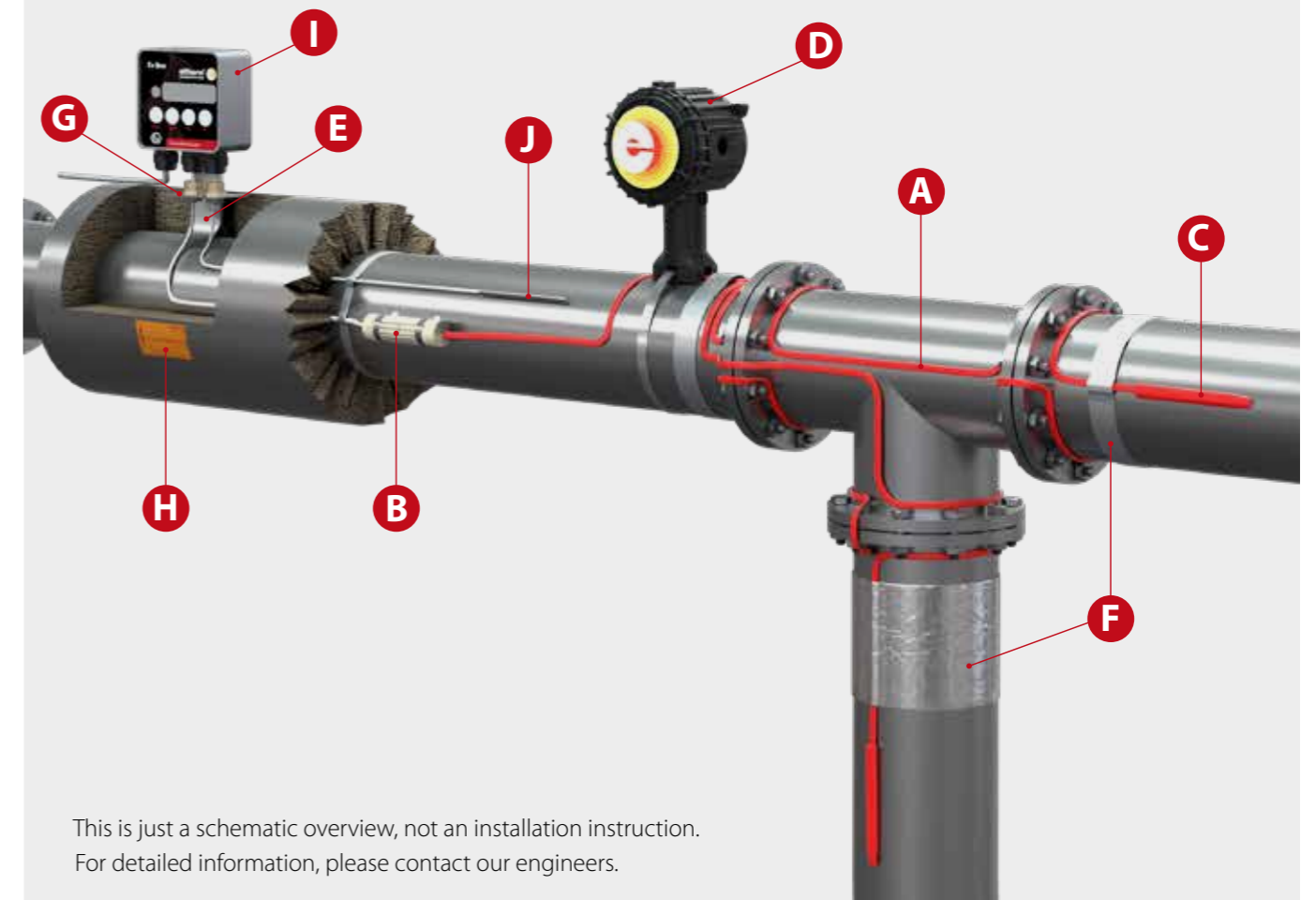

This is just a schematic overview, not an installation instruction. For detailed information, please contact our engineers.

Selection Guide

Type

Applications

Maximum ambient temperature, energized

Maximum ambient temperature, de-energized

Nominal output at 10°C

Max. Heating circuit length at 10°C, 16 ampere, 230 V

Hazardous Areas

Page

Low Temperature

ELSR-N **ELSR-LS** **ELSR-M**

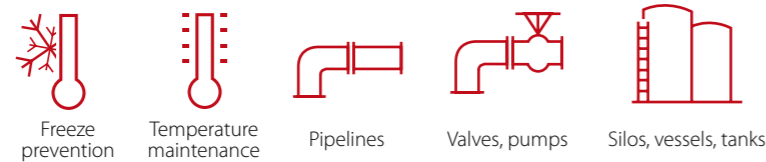

Self-regulating trace heaters for freeze prevention and temperature maintenance in lower temperature ranges, predominantly in industrial applications. ELSR-N and -LS are approved for use in hazardous areas. The BOT version of ELSR-N is resistant to aggressive chemicals, oil and fuel. ELSR-M is very flexible and ideal where small heater dimensions are required.

	65 °C				65 °C			65 °C	
	80 °C				80 °C			65 °C	
	10 W/m	20 W/m	30 W/m	40 W/m	10 W/m	15 W/m	25 W/m	10 W/m	15 W/m
	177,0 m	109,0 m	83,0 m	57,0 m	196,0 m	160,5 m	103,0 m	126,5 m	105,5 m
	●				●				

14 **16** **18**

Low Temperature

ELSR-M-AF/BF

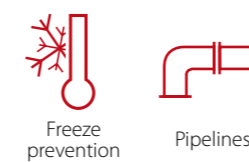

ELSR-M-AF/BF is suited for freeze prevention in pipes and pipelines with seasonal exposure. Typical applications are water supply systems and sanitary facilities on building sites, outdoor events, winter markets etc.

	65 °C	
	65 °C	
	10 W/m	
	89.5 m	

20

Low Temperature

ELSR-R



The ELSR-R line is used where its round geometry facilitates installation in sealing and door profiles. Typical applications are doors and gateways to cold-storage facilities, cold water lines in beverage production and breweries.

	65 °C	
	65 °C	
	19 W/m	27 W/m
	102.0 m	32.0 m

22

Selection Guide

Type

Applications

Maximum ambient temperature, energized

Maximum ambient temperature, de-energized

Nominal output at 10°C

Max. Heating circuit length at 10°C, 16 ampere, 230 V

Hazardous Areas

Page

Medium Temperature						
ELSR-W		ELSR-Ramp		ELSR-FHP		
<p>ELSR-W is employed for temperature maintenance on hot water pipelines and fat disposal lines in canteens or commercial kitchens. It is also used for bacteria and legionella prevention in water lines. ELSR-Ramp for freeze prevention is specially designed for concrete ramps and outdoor surfaces. ELSR-FHP was specially developed for frost heave protection in foundations, for instance in LNG terminals.</p>						
80 °C		80 °C		65 °C (ELSR-FHP-23) 80 °C (ELSR-FHP-38)		
100 °C		100 °C		80 °C (ELSR-FHP-23) 110 °C (ELSR-FHP-38)		
water supply lines 9 W/m at 55 °C	fat/oil 13 W/m at 65 °C	22 W/m at 40 °C	50 W/m at 10 °C	110 W/m at 5 °C	23 W/m at 5 °C	38 W/m at 5 °C
113.0 m	73.5 m		at -10 °C 28.0 m		at -5 °C 48.5 m	at -5 °C 36.5 m
●						
24		26		28		

High Temperature																			
ELSR-H					ELSR-SH					ELSR-SHH									
<p>The ELSR-H, -SH and -SHH high temperature trace heater range is designed for temperature maintenance in industrial processes and applications in hazardous areas. The trace heaters' high chemical resistance allows them to be installed in environments with exposure to aggressive influences.</p>																			
120 °C					165 °C					250 °C									
180 °C					250 °C					250 °C									
10 W/m	15 W/m	20 W/m	30 W/m	45 W/m	60 W/m	75 W/m	15 W/m	35 W/m	45 W/m	75 W/m	90 W/m	15 W/m	30 W/m	45 W/m	60 W/m	75 W/m			
193.0 m	158.0 m	122.0 m	82.0 m	55.0 m	41.0 m	33.0 m	172.0 m	80.0 m	58.0 m	30.0 m	27.0 m	76.0 m	52.0 m	38.0 m	24.0 m	14.0 m			
●																			
30					32					34									

At a Glance

Applications

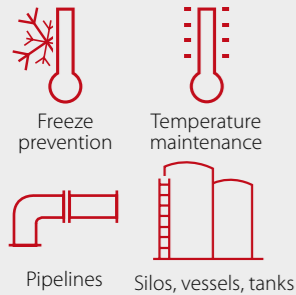

- › Chemistry and Petrochemistry
- › Maritime and offshore
- › Food Processing Industry
- › Water and sanitation utilities

Advantages

- › Four nominal outputs
- › UV-resistant
- › Moisture proof
- › Junction box for pipe mounting

Design



Approvals



- › Cable classification
II 2G Ex 60079-30-1 IIC Gb
II 2D Ex 60079-30-1 IIIC Db
- › System classification
II 2G Ex 60079-30-1 eb IIC T6 Gb
II 2D Ex 60079-30-1 tb IIIC T85°C Db
- › Certification
EPS 18 ATEX 1133 U
EPS 19 ATEX 1014 X
- › Temperature class
T6

Type ELSR-N up to 80 °C

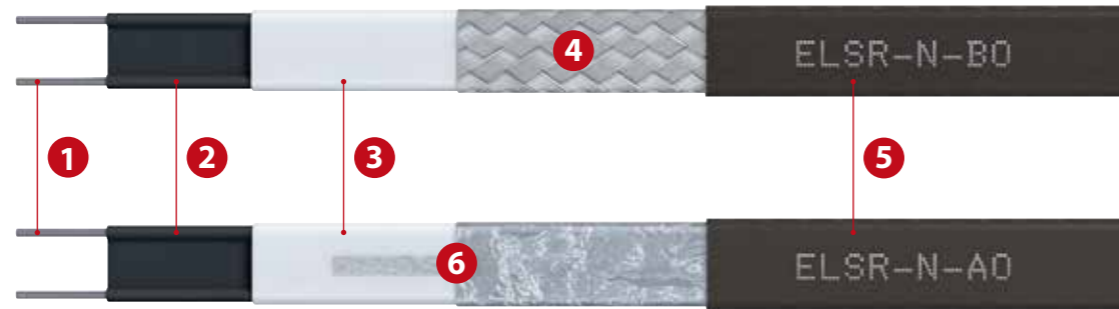

- | | |
|---|---|
| 1 Bus wire
Nickel plated copper | 4 Protection Protective braid (Cu, tin plated) |
| 2 Self-regulating heating element | 5 Outer jacket TPE-O |
| 3 Insulation | 6 Protective conductor connection
see 4 or Cu, tin plated with aluminium foil |

Checklist ELSR-N

B + C Power Connection & End Termination

Code	Description	Part No.
ELVB-SRAN-Ex-20	Power connection, glued, Gland M20, brass	0X81PND
EL-ECN-ex	Silicone termination cap, glued, transparent with ex marking	0X81EN1
ELVB-SREx-25	Power connection, glued, Gland M25 x 1,5, PE	0X81PA1
Ex-Con-SR	Ex connection sleeve Ø 36 x 210 mm 4J	0X81125
ELVB-SREx-IT	Power connection, glued, without gland	091AIT1
ELVB-SRA-25	Power connection, glued, Gland M25 x 1,5, PE	091A010
EL-ECN	Silicone termination cap, glued, transparent	09112N1
ELVB-SRV-N-L-W	Connection set, shrink-fit	0911116
El-Clc P/S	El-Clc P Fast connector with integrated cold lead	09ClcP
	El-Clc S Fast connector T-splice	09ClcS

D Junction Boxes

Code	Description	Part No.
ELAK-Ex-3.5	122 x 120 x 90 mm, 1 heater, capillary thermostat, IP 66	0X80055
ELAK-Ex-3.7	122 x 120 x 90, 1-3 heaters, power supply lead max. 10 mm ² , IP66	0X80057
Ex-it-R	Ø 150 x 125 mm, 3 heaters, 1 Pt100 power supply lead, incl. mounting stand, IP 65	0X80070
ELAK-2	104 x 104 x 70 mm, polycarbonate, breakouts 7x M25, IP 66	0920030
ELAK-5	122 x 120 x 90 mm, polyester, 3 breakouts M25, IP 66	0920013
ELAK-5.1	130 x 130 x 75 mm, polycarbonate, breakouts 9x M20/M25, IP 66	0920002
ELAK-RS-T	150 x 125 mm, twin Pt100, 3 heaters incl. mounting stand, IP 65	0920059

J Temperature Sensors

Code	Description	Part No.
ELTF-PTEx.2	Pt100 4 conductor, 3 m PTFE cable	0X70002
ELTF-PTEx.4	2x Pt100 3 conductor, 3 m cold lead	0X70030
ELTF-PT.1	Pt100, 5 x 50 mm PVC 5 m	0650001
ELTF-PT.3	Pt100, 2 conductor, 5 x 50 mm, 3 m PTFE cable	0650003
ELTF-PT.3.1	Pt100, 3 conductor, 5 x 50 mm, 3 m PTFE cable	0650002

Technical Information

Maximum ambient temperature, energized	65 °C
Maximum ambient temperature, de-energized	80 °C
Nominal voltage*	230 V
Bending radius, min.	25 mm
Installation temperature, min.	-60 °C

*Further power inputs on request

Heating circuit lengths on the following conditions

- › 230 V nominal voltage
- › Delayed action circuit breakers (C-characteristic) with 80 % maximum load
- › Maximum 10 % line voltage drop on heating cable bus wire
- › Power connection to one heater end

ELSR-N...-2 output

(on insulated metallic pipes in accordance with EN 62395-1)

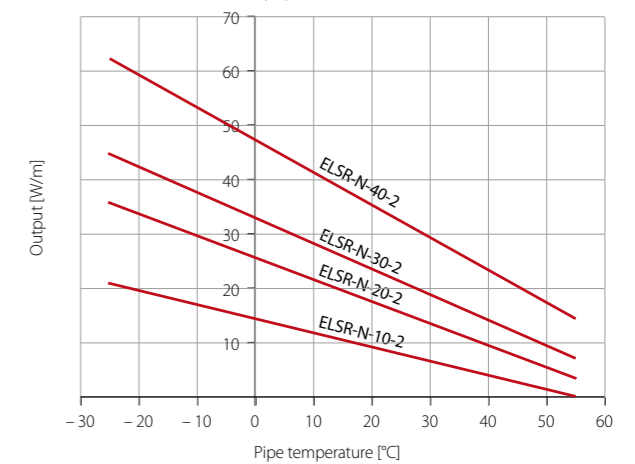

Switch-on temperature (°C)	Nominal cutout value (A)	Heating circuit length (m) for			
		ELSR-N-10-2	ELSR-N-20-2	ELSR-N-30-2	ELSR-N-40-2
10	10	128.0	68.0	52.0	36.0
	16	177.0	109.0	83.0	57.0
	20	177.0	129.0	104.0	71.0
	25	177.0	129.0	113.0	89.0
	32	177.0	129.0	113.0	94.0
0	10	106.0	57.0	45.0	31.0
	16	160.0	92.0	71.0	50.0
	20	160.0	115.0	89.0	62.0
	25	160.0	119.0	105.0	78.0
	32	160.0	119.0	105.0	88.0
-10	10	90.0	50.0	39.0	28.0
	16	144.0	79.0	63.0	44.0
	20	149.0	99.0	78.0	55.0
	25	149.0	111.0	98.0	69.0
	32	149.0	111.0	98.0	83.0
-20	10	78.0	44.0	35.0	25.0
	16	125.0	70.0	56.0	40.0
	20	139.0	87.0	69.0	50.0
	25	139.0	104.0	87.0	62.0
	32	139.0	104.0	87.0	78.0
-40	10	62.0	35.0	28.0	21.0
	16	99.0	56.0	45.0	33.0
	20	124.0	71.0	57.0	42.0
	25	124.0	88.0	71.0	52.0
	32	124.0	88.0	71.0	66.0

Type	Nominal output	Dimensions approx. (mm)	Weight approx. (g/m)	Part No.
ELSR-N-10-2-AO	10 W/m at 10 °C	13.6 x 5.5	91	B0200130
ELSR-N-10-2-BO	10 W/m at 10 °C	14.1 x 5.8	108	B0200110
ELSR-N-10-2-BOT	10 W/m at 10 °C	13.8 x 5.6	108	B0200119
ELSR-N-20-2-AO	20 W/m at 10 °C	13.6 x 5.5	91	B0200230
ELSR-N-20-2-BO	20 W/m at 10 °C	14.1 x 5.8	108	B0200210
ELSR-N-20-2-BOT	20 W/m at 10 °C	13.8 x 5.6	108	B0200219
ELSR-N-30-2-AO	30 W/m at 10 °C	13.6 x 5.5	91	B0200330
ELSR-N-30-2-BO	30 W/m at 10 °C	14.1 x 5.8	108	B0200310
ELSR-N-30-2-BOT	30 W/m at 10 °C	13.8 x 5.6	108	B0200319
ELSR-N-40-2-AO	40 W/m at 10 °C	13.6 x 5.5	91	B0200430
ELSR-N-40-2-BO	40 W/m at 10 °C	14.1 x 5.8	108	B0200410
ELSR-N-40-2-BOT	40 W/m at 10 °C	13.8 x 5.6	108	B0200419

At a Glance

Applications

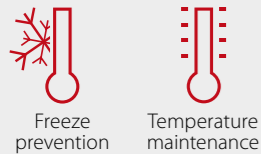

- › Chemistry and Petrochemistry
- › Maritime and offshore
- › Food Processing Industry
- › Water and sanitation utilities

Advantages

- › Three nominal outputs
- › UV-resistant
- › Moisture proof
- › Small dimensions

Design



Approvals



- › Cable classification
EPS II 2G Ex 60079-30-1 IIC Gb
EPS II 2D Ex 60079-30-1 IIIC Db
- › System classification
IBExU II 2G Ex 60079-30-1 eb IIC T6 Gb
II 2D Ex 60079-30-1 tb IIIC TX Db
- › Certification
EPS 19 ATEX 1 215 U
IBExU 09 ATEX 1047 X
- › Temperature class
T6

Type ELSR-LS up to 80 °C



- | | |
|--|---|
| <p>1 Bus wire
Nickel plated copper</p> <p>2 Self-regulating heating element</p> <p>3 Insulation</p> | <p>4 Protection Protective braid (Cu, tin plated)</p> <p>5 Outer jacket TPE-O</p> <p>6 Protective conductor connection
see 4 or Cu, tin plated with aluminium foil</p> |
|--|---|

Checklist ELSR-LS

B + C Power Connection & End Termination

Part No.	Description	Part No.
ELVB-SREx-25	Power connection, glued, Gland M25 x 1,5, PE	0X81PA1
ELVB-SRAL-Ex-20	Power connection, glued, Gland M20, brass	0X81PLD
EL-ECL-ex	Silicone termination cap, glued, transparent with ex marking	0X81EL1
Ex-Con-SR	Ex connection sleeve Ø 36 x 210 mm 4J	0X81125
ELVB-SRA-25	Power connection, glued, Gland M25 x 1,5, PE	091A010
ELVB-SRV-N-L-W	Connection set, shrink-fit	0911116
EL-ECL	Silicone termination cap, glued, transparent	09112L1
El-Clie P/S	El-Clie P Fast connector with integrated cold lead	09ClieP
	El-Clie S Fast connector T-splice	09ClieS

D Junction Boxes

Part No.	Description	Part No.
ELAK-Ex-3.5	122 x 120 x 90 mm, 1 heater, capillary thermostat, IP 66	0X80055
ELAK-Ex-3.7	122 x 120 x 90, 1-3 heaters, power supply lead max. 10 mm ² , IP66	0X80057
ELAK-2	104 x 104 x 70 mm, polycarbonate, breakouts 7x M25, IP 66	0920030
ELAK-5	122 x 120 x 90 mm, polyester, 3 breakouts M25, IP 66	0920013
ELAK-5.1	130 x 130 x 75 mm, polycarbonate, breakouts 9x M20/M25, IP 66	0920002
ELAK-RS-T	150 x 125 mm, twin Pt100, 3 heaters incl. mounting stand, IP 65	0920059

J Temperature Sensors

Part No.	Description	Part No.
ELTF-PTEx.2	Pt100 4 conductor, 3 m PTFE cable	0X70002
ELTF-PTEx.4	2x Pt100 3 conductor, 3 m cold lead	0X70030
ELTF-PT.1	Pt100, 5 x 50 mm PVC 5 m	0650001
ELTF-PT.3	Pt100, 2 conductor, 5 x 50 mm, 3 m PTFE cable	0650003
ELTF-PT.3.1	Pt100, 3 conductor, 5 x 50 mm, 3 m PTFE cable	0650002

Technical Information

Maximum ambient temperature, energized	65 °C
Maximum ambient temperature, de-energized	80 °C
Nominal voltage*	230 V
Bending radius, min.	25 mm
Installation temperature, min.	-60 °C

*Further power inputs on request

Heating circuit lengths on the following conditions

- › 230 V nominal voltage
- › Delayed action circuit breakers (C-characteristic) with 80 % maximum load
- › Maximum 10 % line voltage drop on heating cable bus wire
- › Power connection to one heater end

ELSR-LS-...-2 output

(on insulated metallic pipes in accordance with EN 62395-1)

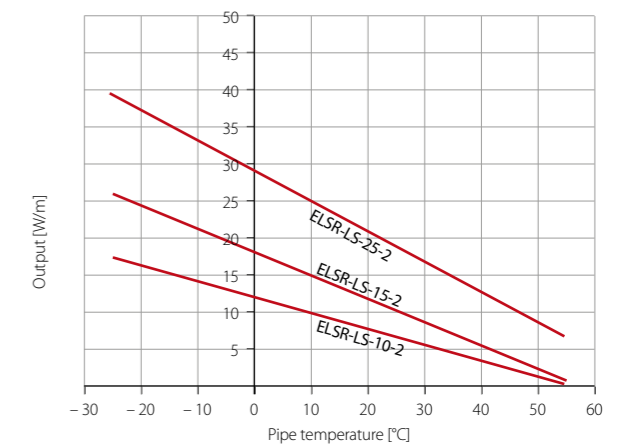

Switch-on temperature (°C)	Nominal output value (A)	Heating circuit length (m) for		
		ELSR-LS-10-2	ELSR-LS-15-2	ELSR-LS-25-2
10	10	152.0	103.0	64.0
	16	196.0	160.5	103.0
	20	196.0	160.5	126.0
	25	196.0	160.5	126.0
0	10	141.0	84.0	54.0
	16	188.5	134.0	87.0
	25	188.5	145.0	116.0
-10	10	119.0	71.0	47.0
	16	173.5	114.0	75.0
	25	173.5	133.0	107.5
-20	10	103.0	62.0	37.5
	16	161.0	99.0	60.0
	25	161.0	124.0	94.0

Type	Nominal output	Dimensions approx. (mm)	Weight approx. (g/m)	Part No.
ELSR-LS-10-2-BO	10 W/m at 10 °C	11,0 x 5,6	98	B0223102
ELSR-LS-10-2-AO	10 W/m at 10 °C	10,3 x 5,3	78	B0223104
ELSR-LS-15-2-BO	15 W/m at 10 °C	11,0 x 5,6	98	B0223152
ELSR-LS-15-2-AO	15 W/m at 10 °C	10,3 x 5,3	78	B0223154
ELSR-LS-25-2-BO	25 W/m at 10 °C	11,0 x 5,6	98	B0223252
ELSR-LS-25-2-AO	25 W/m at 10 °C	10,3 x 5,3	78	B0223254

At a Glance

Applications

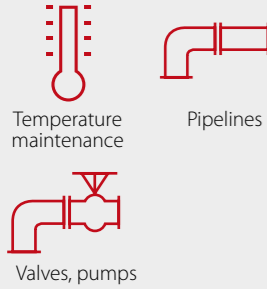

- › Chemistry and Petrochemistry
- › Food Processing Industry
- › Water and sanitation utilities

Advantages

- › Two nominal outputs
- › UV-resistant
- › Moisture proof
- › Small dimensions

Design



Zulassungen



Type ELSR-M

up to 65 °C

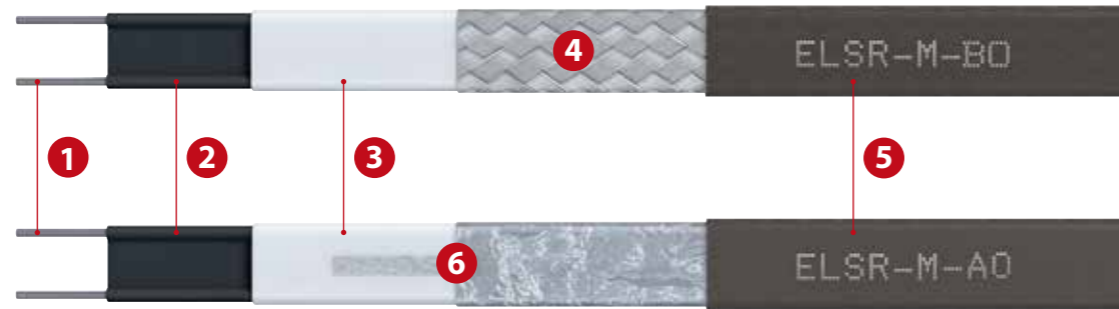

1 Bus wire	Nickel plated copper
2 Self-regulating heating element	
3 Insulation	
4 Protection	Protective braid (Cu, tin plated)
5 Outer jacket	TPE-O
6 Protective conductor connection	see 4 or Cu, tin plated with aluminium foil

Checklist ELSR-M

B + C Power Connection & End Termination		
ELVB-SRAM-25	Power connection, shrink-fit, Gland M25 x 1,5, PE	091A015
EL-ECM	Silicone termination cap, glued, transparent	09112M1
ELVB-SRV-M	Connection set, shrink-fit	0911122
D Junction Boxes		
ELAK-2	104 x 104 x 70 mm, polycarbonate, breakouts 7x M25, IP 66	0920030
ELAK-5	122 x 120 x 90 mm, polyester, 3 breakouts M25, IP 66	0920013
ELAK-5.1	130 x 130 x 75 mm, polycarbonate, breakouts 9x M20/M25, IP 66	0920002
J Temperature Sensors		
ELTF-PT.1	Pt100, 5 x 50 mm PVC 5 m	0650001
ELTF-PT.3	Pt100, 2 conductor, 5 x 50 mm, 3 m PTFE cable	0650003
ELTF-PT.3.1	Pt100, 3 conductor, 5 x 50 mm, 3 m PTFE cable	0650002

Technical Information

Maximum ambient temperature, energized	65 °C
Maximum ambient temperature, de-energized	65 °C
Nominal voltage	230 V
Bending radius, min.	25 mm
Installation temperature, min.	-45 °C

Heating circuit lengths on the following conditions

- › 230 V nominal voltage
- › Delayed action circuit breakers (C-characteristic) with 80 % maximum load
- › Maximum 10 % line voltage drop on heating cable bus wire
- › Power connection to one heater end

ELSR-M-...-2 output

(on insulated metallic pipes in accordance with EN 62395-1)

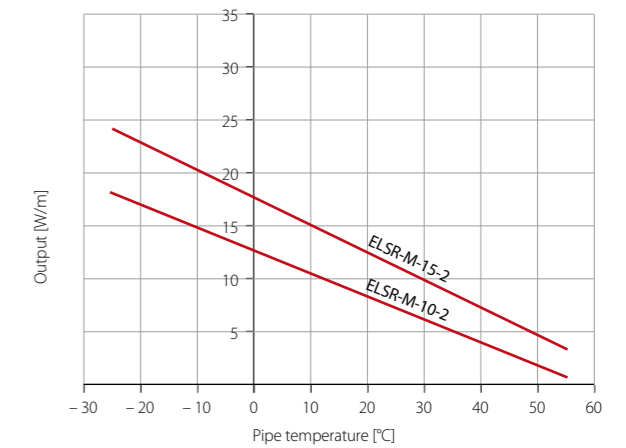

Switch-on temperature (°C)	Nominal cutout value (A)	Heating circuit length (m) for	
		ELSR-M-10-2	ELSR-M-15-2
10	10	126.5	98.0
	16	126.5	105.5
	20	126.5	105.5
0	10	115.5	83.0
	16	115.5	97.5
	20	115.5	97.5
-10	10	100.0	72.0
	16	106.5	91.0
	20	106.5	91.0
-20	10	87.0	64.0
	16	99.5	85.5
	20	99.5	85.5
-40	10	69.0	52.0
	16	88.5	77.0
	20	88.5	77.0

Type	Nominal output	Dimensions approx. (mm)	Weight approx. (g/m)	Part No.
ELSR-M-10-2-AO	10 W/m at 10 °C	8,0 x 5,5	53	B0225110
ELSR-M-10-2-BO	10 W/m at 10 °C	8,5 x 5,8	62	B0225102
ELSR-M-15-2-AO	15 W/m at 10 °C	8,0 x 5,5	53	B0225160
ELSR-M-15-2-BO	15 W/m at 10 °C	8,5 x 5,8	62	B0225152

At a Glance

Applications

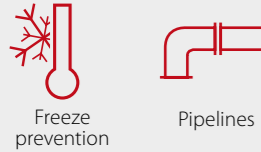

- › In-pipe trace heating approved for potable water pipes and flexible tubes

Advantages

- › Officially approved
- › Can be used in liquids
- › Suitable for drinking water
- › Small dimensions

Design



Approvals



- › Certification K-229437-13-Bs/st

Type ELSR-M-AF/BF up to 65 °C

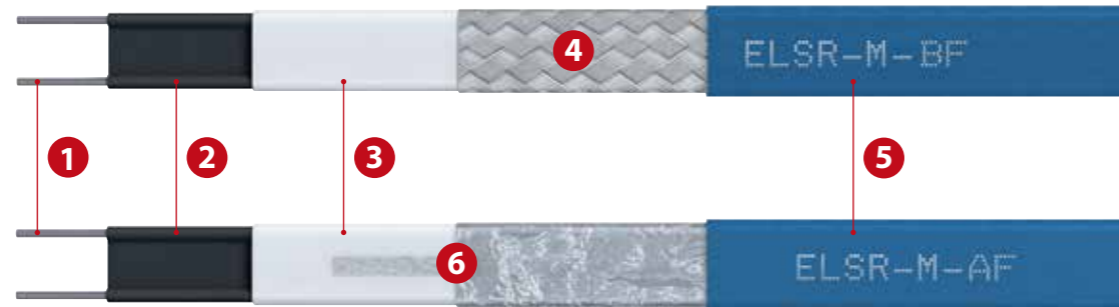

1 Bus wire	Nickel plated copper
2 Self-regulating heating element	
3 Insulation	
4 Protection	Protective braid (Cu, tin plated)
5 Outer jacket	TPE-O
6 Protective conductor connection	see 4 or Cu, tin plated with aluminium foil

Checklist ELSR-M-AF/BF

B + C Power Connection & End Termination		
ELVB-70	Cable gland Ms 3/4", brass, approved for drinking water	0911703
ELVB-71	Y-connector 32 mm, brass, approved for drinking water	0911704
ELVB-SRAM-25	Power connection, shrink-fit, Gland M25 x 1,5, PE	091A015
EL-ECMF	Silicone termination cap, glued, transparent	09112MF
ELVB-SRV-M	Connection set, shrink-fit	0911122
D Junction Boxes		
ELAK-2	104 x 104 x 70 mm, polycarbonate, breakouts 7x M25, IP 66	0920030
ELAK-5	122 x 120 x 90 mm, polyester, 3 breakouts M25, IP 66	0920013
ELAK-5.1	130 x 130 x 75 mm, polycarbonate, breakouts 9x M20/M25, IP 66	0920002
J Temperature Sensors		
ELTF-PT.1	Pt100, 5 x 50 mm PVC 5 m	0650001
ELTF-PT.3	Pt100, 2 conductor, 5 x 50 mm, 3 m PTFE cable	0650003
ELTF-PT.3.1	Pt100, 3 conductor, 5 x 50 mm, 3 m PTFE cable	0650002

Technical Information

Maximum ambient temperature, energized	65 °C
Maximum ambient temperature, de-energized	65 °C
Nominal voltage	230 V
Bending radius, min.	25 mm
Installation temperature, min.	-45 °C

Heating circuit lengths on the following conditions

- › 230 V nominal voltage
- › Delayed action circuit breakers (C-characteristic) with 80 % maximum load
- › Maximum 10 % line voltage drop on heating cable bus wire
- › Power connection to one heater end

ELSR-M-10-2-AF/BF output (in a filled water pipeline)

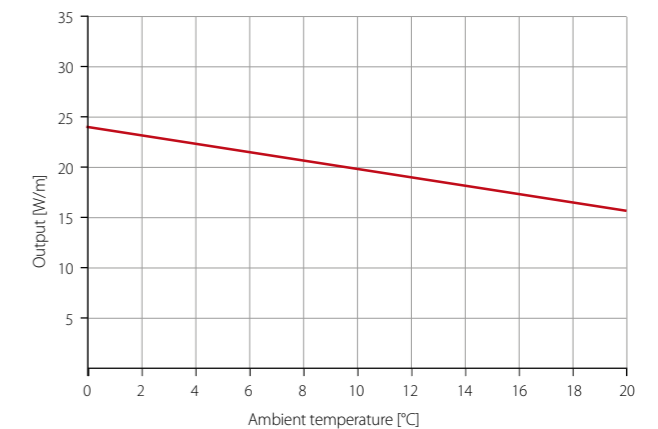

Switch-on temperature (°C)	Nominal cutout value (A)	Heating circuit length (m) for	
		ELSR-M-10-2-AF/BF	
10	10	74.0	
	16	89.5	
	20	89.5	
0	10	61.5	
	16	89.5	
	20	89.5	
-30	10	61.5	
	16	89.5	
	20	89.5	

Type	Nominal output	Dimensions approx. (mm)	Weight approx. (g/m)	Part No.
ELSR-M-10-2-BF	10 W/m at 10 °C	7.5 x 4.9	62	B0225104
ELSR-M-10-2-AF	10 W/m at 10 °C	7.0 x 4.6	53	B0225105

At a Glance

Applications



Freeze prevention



Special solutions

- › Doors and seals of refrigerating chambers
- › Profile heating
- › Boarding Bridges

Advantages

- › Round design
- › Moisture proof
- › UV-resistant
- › Ideal for profile installation

Design

BOT

Approvals



Type ELSR-R

up to 65 °C

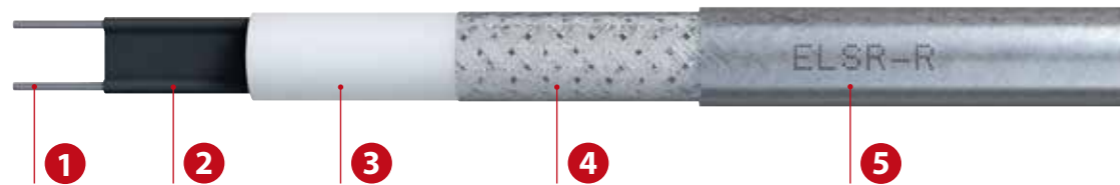

1 Bus wire	Nickel plated copper
2 Self-regulating heating element	
3 Insulation	
4 Protection	Protective braid (Cu, tin plated)
5 Outer jacket	Fluoropolymer

Checklist ELSR-R

B + C Power Connection & End Termination

ELVB-SRAR-25	Power connection, shrink-fit, Gland M25 x 1,5, PE	091A020
EL-ECM	Silicone termination cap, glued, transparent	09112M1
ELVB-SRV-M	Connection set, shrink-fit	0911122

D Junction Boxes

ELAK-2	104 x 104 x 70 mm, polycarbonate, breakouts 7x M25, IP 66	0920030
ELAK-5	122 x 120 x 90 mm, polyester, 3 breakouts M25, IP 66	0920013
ELAK-5.1	130 x 130 x 75 mm, polycarbonate, breakouts 9x M20/M25, IP 66	0920002

J Temperature Sensors

ELTF-PT.1	Pt100, 5 x 50 mm PVC 5 m	0650001
ELTF-PT.3	Pt100, 2 conductor, 5 x 50 mm, 3 m PTFE cable	0650003
ELTF-PT.3.1	Pt100, 3 conductor, 5 x 50 mm, 3 m PTFE cable	0650002

Technical Information

Maximum ambient temperature, energized	65 °C
Maximum ambient temperature, de-energized	65 °C
Nominal voltage	230 V
Bending radius, min.	30 mm
Installation temperature, min.	-30 °C

Heating circuit lengths on the following conditions

- › 230 V nominal voltage
- › Delayed action circuit breakers (C-characteristic) with 80 % maximum load
- › Maximum 10 % line voltage drop on heating cable bus wire
- › Power connection to one heater end

ELSR-R-...-2-BOT output

(in a filled water pipeline)

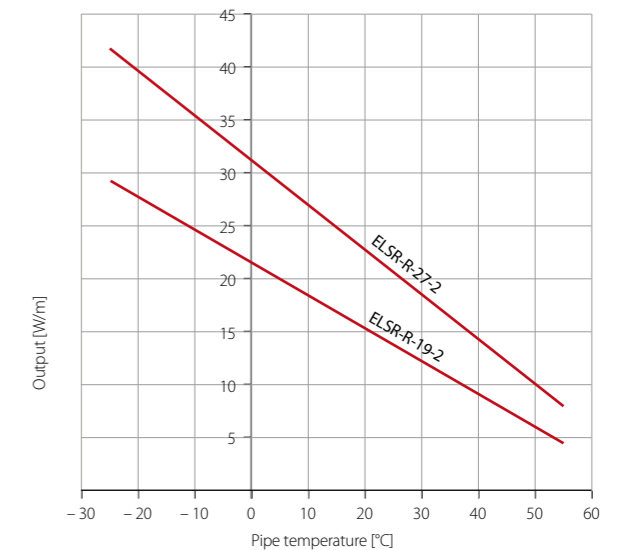

Switch-on temperature (°C)	Nominal cutout value (A)	Heating circuit length (m) for	
		ELSR-R-19-2	ELSR-R-27-2
10	10	75.0	20.0
	16	102.0	32.0
	20	102.0	40.0
0	10	62.0	16.5
	16	94.0	26.5
	20	94.0	33.0
-10	10	51.0	13.5
	16	81.5	21.5
	20	88.0	27.0
-20	10	41.0	11.0
	16	65.5	17.5
	20	82.0	22.0
-40	10	30.0	7.5
	16	48.0	12.0
	20	60.0	15.0

Type	Nominal output	Dimensions approx. (mm)	Weight approx. (g/m)	Part No.
ELSR-R-19-2-BOT	19 W/m at 10 °C	7.3	77	B0200507
ELSR-R-27-2-BOT	27 W/m at 10 °C	7.3	74	B0200605

Other versions are available upon request. This heating cable has specially been developed for the use with doors of refrigerating chambers. Please contact our engineers for more details on our ELSR-R.

At a Glance

Applications

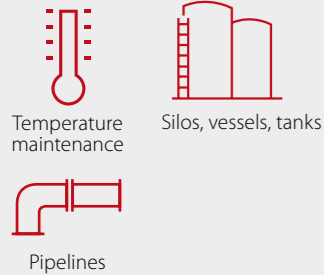

- › Fat-containing wastewater pipes in canteens and large-scale kitchens
- › Legionella prevention on hot water pipes

Advantages

- › Two nominal outputs
- › Moisture proof

Design



Approvals

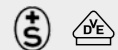

Type ELSR-W

up to 100 °C



1 Bus wire	Nickel plated copper
2 Self-regulating heating element	
3 Insulation	
4 Protection	Protective braid (Cu, tin plated)
5 Outer jacket	TPE-O
6 Protective conductor connection	see 4 or Cu, tin plated with aluminium foil

Checklist ELSR-W

B + C Power Connection & End Termination

ELVB-SRA-25	Power connection, glued, Gland M25 x 1,5, PE	091A010
EL-ECW	Silicone termination cap, glued, transparent	09112W1
ELVB-SRV-N-L-W	Connection set, shrink-fit	0911116
El-Click P/S	El-Click P Fast connector with integrated cold lead	09ClickP
	El-Click S Fast connector T-splice	09ClickS

D Junction Boxes

ELAK-2	104 x 104 x 70 mm, polycarbonate, breakouts 7x M25, IP 66	0920030
ELAK-5	122 x 120 x 90 mm, polyester, 3 breakouts M25, IP 66	0920013
ELAK-5.1	130 x 130 x 75 mm, polycarbonate, breakouts 9x M20/M25, IP 66	0920002
ELAK-RS-T	150 x 125 mm, twin Pt100, 3 heaters incl. mounting stand, IP 65	0920059

J Temperature Sensors

ELTF-PT.1	Pt100, 5 x 50 mm PVC 5 m	0650001
ELTF-PT.3	Pt100, 2 conductor, 5 x 50 mm, 3 m PTFE cable	0650003
ELTF-PT.3.1	Pt100, 3 conductor, 5 x 50 mm, 3 m PTFE cable	0650002

Technical Information

Maximum ambient temperature, energized	80 °C
Maximum ambient temperature, de-energized	100 °C
Nominal voltage	230 V
Bending radius, min.	20 mm
Installation temperature, min.	-20 °C

Heating circuit lengths on the following conditions

- › 230 V nominal voltage
- › Delayed action circuit breakers (C-characteristic) with 80 % maximum load
- › Maximum 10 % line voltage drop on heating cable bus wire
- › Power connection to one heater end

ELSR-W-...-2 output

(on insulated metallic pipes in accordance with EN 62395-1)

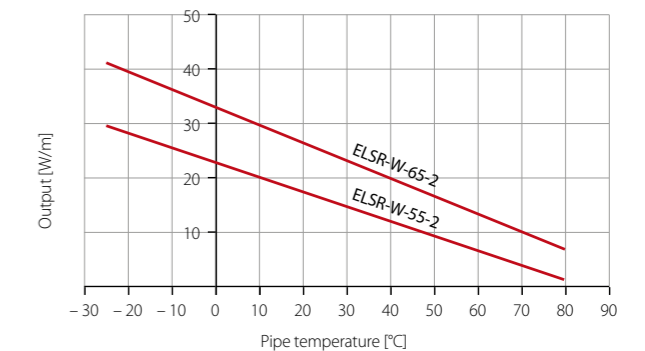

Switch-on temperature (°C)	Nominal cutout value (A)	Heating circuit length (m) for	
		ELSR-W-55-2	ELSR-W-65-2
10	10	70.0	45.5
	16	113.0	73.5
	20	131.0	92.0
	25	131.0	106.0
0	32	131.0	106.0
	10	63.0	41.5
	16	101.0	66.0
	20	123.5	83.0
-10	25	123.5	99.5
	32	123.5	99.5
	10	57.0	37.5
	16	91.0	60.0
-20	20	113.5	75.0
	25	117.0	94.0
	32	117.0	95.0
	10	52.0	34.0
-40	16	83.0	55.0
	20	104.0	69.5
	25	112.0	86.0
	32	112.0	90.5
	10	44.0	29.5
	16	70.0	48.0
	20	88.0	59.0
	25	103.0	74.0
	32	103.0	83.5

Type	Nominal output used for water supply lines	Dimensions approx. (mm)	Weight approx. (g/m)	Part No.
ELSR-W-55-2-AO	9 W/m at 55 °C	12.9 x 5.0	86	B0200360
ELSR-W-55-2-BO	9 W/m at 55 °C	12.9 x 5.0	105	B0200350
ELSR-W-65-2-AO	13 W/m at 65 °C	12.9 x 5.0	86	B0200455
ELSR-W-65-2-BO	13 W/m at 65 °C	12.9 x 5.0	105	B0200450

Type	Nominal output used with fat/oil lines	Dimensions approx. (mm)	Weight approx. (g/m)	Part No.
ELSR-W-65-2-AO	22 W/m at 40 °C	12.9 x 5.0	86	B0200455
ELSR-W-65-2-BO	22 W/m at 40 °C	12.9 x 5.0	105	B0200450

At a Glance

Applications



Freeze prevention



Open area

- › Parking garages entrances, exits
- › Helicopter landing sites
- › Concrete ramps
- › Stairs and footpaths

Advantages

- › Highly robust
- › Suited for hardest installing conditions
- › Flexible mounting
- › Radially and longitudinally waterproof
- › Outer jacket is strongly grouted with protective braid

Approvals



Note

- › Not suited for use in asphalt

Type ELSR-Ramp up to 100 °C

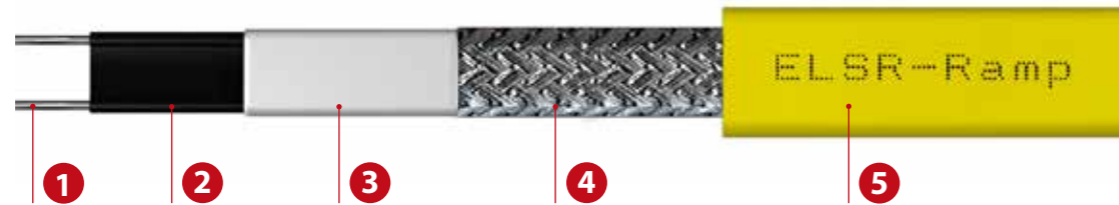

1 Bus wire	Nickel plated copper
2 Self-regulating heating element	
3 Insulation	
4 Protection	Protective braid (Cu, tin plated)
5 Outer jacket	TPE pressure-grouted with protective braid

Checklist ELSR-Ramp

B + C Power Connection & End Termination

ELVB-SRV-Ramp	Connection set, shrink-fit	0911124
EL-ECRA	Silicone termination cap, glued, transparent	09112RA

D Junction Boxes

ELAK-5	122 x 120 x 90 mm, polyester, 3 breakouts M25, IP 66	0920013
ELAK-5.1	130 x 130 x 75 mm, polycarbonate, breakouts 9x M20/M25, IP 66	0920002

J Temperature Sensors

Sensor Set	Sensor set for ELSR-Ramp	TBA000202
------------	--------------------------	-----------

Technical Information

Maximum ambient temperature, energized	80 °C
Maximum ambient temperature, de-energized	100 °C
Nominal voltage	230 V
Bending radius, min.	50 mm
Installation temperature, min.	-20 °C

Heating circuit lengths on the following conditions

- › 230 V nominal voltage
- › Delayed action circuit breakers (C-characteristic) with 80 % maximum load
- › Maximum 10 % line voltage drop on heating cable bus wire
- › Power connection to one heater end

Switch-on temperature (°C)	Nominal cutout value (A)	Heating circuit length (m) for	
		ELSR-Ramp	
-10	10	18.0	
	16	28.0	
	20	36.0	
	25	45.0	
	32	55.0	

Type	Nominal output	Dimensions approx. (mm)	Weight approx. (g/m)	Part No.
ELSR-Ramp	50 W/m at 10 °C	17,2 x 9,5	253	B02RAMP0
ELSR-Ramp	110 W/m at 5 °C in concrete	17,2 x 9,5	253	B02RAMP0

Heating circuit lengths may vary in specific installation situations. Please contact our engineers for more details.

Electrical protection

Maximum heating circuit length

- › According to local standards and regulations.
- › Take into account the supply lead conductor size and max. permitted voltage drop.
- › A higher voltage drop can occur at start-up of heating.

Power at start-up

- › According to local standards and regulations.
- › To determine the installed power with the electrical system designer, the nominal current of the series connected fuse or the current value at the system start-up temperature must be taken into account (e.g. 32 A for 55 m ELSR-Ramp (-10 °C)).
- › Residual current device (RCD) 30 mA required, max. 500 m heating cable per RCD.

Remark

- › For the use of standard control cabinets, the maximum heating circuit length of 55 m at 32 A per heating circuit must not be exceeded.

At a Glance

Applications

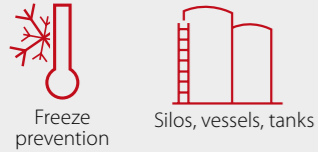

› Cryogenic Storage Tanks

Advantages

- › Highly robust
- › Suitable for harsh installed environment
- › Flexible mounting
- › Waterproof

Approvals



- › Cable classification
EPS II 2G Ex 60079-30-1 IC Gb
EPS II 2D Ex 60079-30-1 IIIC Db
- › System classification
II 2G Ex 60079-30-1 eb IIC Gb
II 2D Ex 60079-30-1 tb IIIC Db
- › Certification
EPS 14 ATEX 1 653 X
EPS IECEx 14.0021U

Type ELSR-FHP up to 110 °C

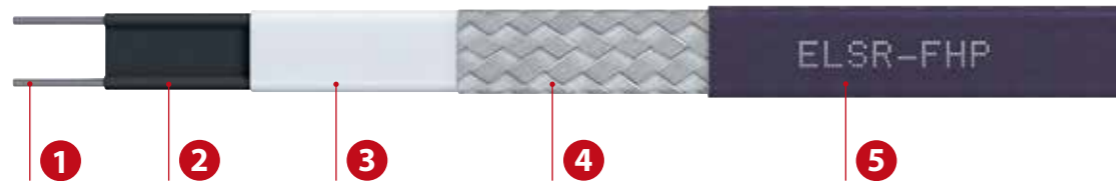

1 Bus wire	Nickel plated copper
2 Self-regulating heating element	
3 Insulation	
4 Protection	Protective braid (Cu, tin plated)
5 Outer jacket	Fluoropolymer

Checklist ELSR-FHP

B + C Power Connection & End Termination

EL-ECFHP-Ex	End termination kit for ELSR-FHP	0X81FH1
ELVB-SREx-25	Power connection, glued, Gland M25 x 1,5, PE	0X81PA1
EL-ECFHP	End termination kit for ELSR-FHP	09112F1
ELVB-SRA-25	Power connection, glued, Gland M25 x 1,5, PE	091A010

D Junction Boxes

ELAK-Ex-3.5	122 x 120 x 90 mm, 1 heater, capillary thermostat, IP 66	0X80055
ELAK-Ex-3.7	122 x 120 x 90, 1-3 heaters, power supply lead max. 10 mm ² , IP66	0X80057
ELAK-2	104 x 104 x 70 mm, polycarbonate, breakouts 7x M25, IP 66	0920030
ELAK-5	122 x 120 x 90 mm, polyester, 3 breakouts M25, IP 66	0920013
ELAK-5.1	130 x 130 x 75 mm, polycarbonate, breakouts 9x M20/M25, IP 66	0920002

J Temperature Sensors

ELTF-PTEx.2	Pt100 4 conductor, 3 m PTFE cable	0X70002
ELTF-PTEx.4	2x Pt100 3 conductor, 3 m cold lead	0X70030
ELTF-PT.1	Pt100, 5 x 50 mm PVC 5 m	0650001
ELTF-PT.3	Pt100, 2 conductor, 5 x 50 mm, 3 m PTFE cable	0650003
ELTF-PT.3.1	Pt100, 3 conductor, 5 x 50 mm, 3 m PTFE cable	0650002

Technical Information

Maximum ambient temperature, energized	80 °C (ELSR-FHP-38)
	65 °C (ELSR-FHP-23)
Maximum ambient temperature, de-energized	110 °C (ELSR-FHP-38)
	80 °C (ELSR-FHP-23)
Nominal voltage	230 V
Bending radius, min.	50 mm
Installation temperature, min.	-45 °C

Heating circuit lengths on the following conditions

- › 230 V nominal voltage
- › Delayed action circuit breakers (C-characteristic) with 80 % maximum load
- › Maximum 10 % line voltage drop on heating cable bus wire
- › Power connection to one heater end, in 25 mm/1" conduit

ELSR-FHP-...-2 output

(in empty metallic protection pipes 1")

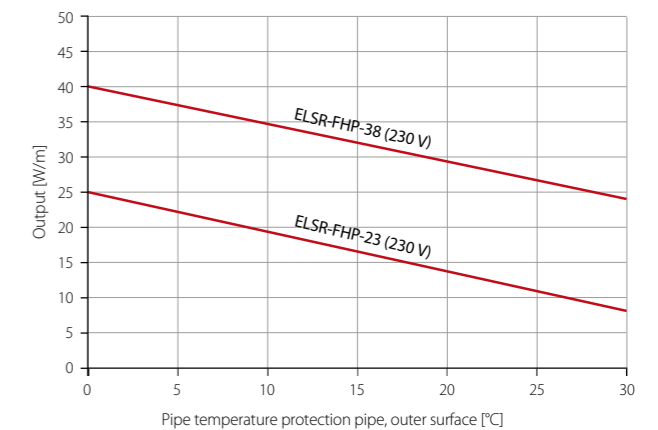

Switch-on temperature (°C)	Nominal cutout value (A)	Heating circuit length (m) for	
		ELSR-FHP-23	ELSR-FHP-38
-5	10	30.0	23.0
	16	48.5	36.5
	20	60.5	45.5
	25	75.5	57.5
	32	97.0	72.5
	40	121.0	91.5
-15	10	23.0	21.5
	16	37.0	34.5
	20	46.0	43.0
	25	57.5	54.0
	32	74.5	68.5
	40	92.0	85.5

Type	Nominal output	Dimensions approx. (mm)	Weight approx. (g/m)	Part No.
ELSR-FHP-23	23 W/m at 5 °C	14,0 x 5,5	155	B02FHP23
ELSR-FHP-38	38 W/m at 5 °C	14,0 x 5,5	155	B02FHP38

Heating circuit lengths may vary in specific installation situations. Please contact our engineers for more details.

At a Glance

Applications

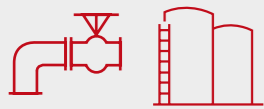
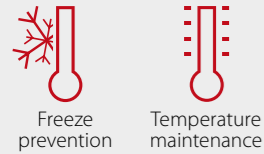

Valves, pumps Silos, vessels, tanks

- › Chemistry and Petrochemistry
- › Oil and Gas Industry
- › Power plants
- › Water and sanitation utilities

Advantages

- › Seven nominal outputs
- › Moisture proof
- › Resistant to chemicals
- › Use in hazardous areas

Design

BOT

Approvals



- › Cable classification
 - II 2G Ex 60079-30-1 IIC Gb
 - II 2D Ex 60079-30-1 IIIC Db
- › System classification
 - IBExU II 2G Ex e IIC T3 Gb
 - II 2G Ex 60079-30-1 eb IIC T3 Gb
 - IBExU II 2G Ex e IIC T4...T6 Gb
 - II 2D Ex 60079-30-1 tb IIIC T200°C Db
- › Certification
 - EPS 12 ATEX 1 429 U
 - EPS 19 ATEX 1013 X
- › Temperature class
 - T3 to T6

Type ELSR-H

up to 180 °C

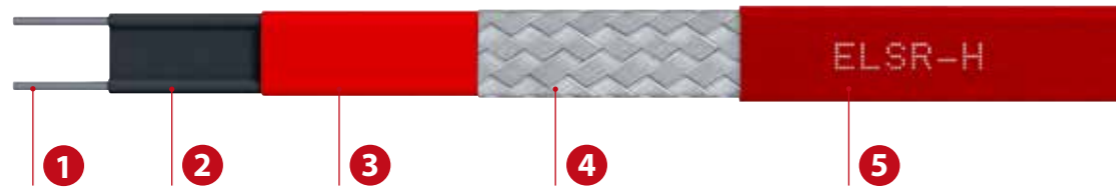

1 Bus wire	Nickel plated copper
2 Self-regulating heating element	
3 Insulation	
4 Protection	Protective braid (Cu, tin plated)
5 Outer jacket	TPE-O, Fluoropolymer

Checklist ELSR-H

B + C Power Connection & End Termination

EL-ECSH-Ex	Silikonendkappe rot, Klebetechnik, mit Ex-Aufdruck	0X81EH2
Ex-Con-SR	Ex connection sleeve Ø 36 x 210 mm 4J	0X81125
ELVB-SREx-25	Power connection, glued, Gland M25 x 1,5, PE	0X81PA1
ELVB-SREx-IT	Power connection, glued, without gland	091AIT1
ELVB-SRV-H	Connection set, shrink-fit	0911117
ELVB-SRAH-25	Power connection, glued, Gland M25 x 1,5, PE	091A040

D Junction Boxes

ELAK-Ex-3.7	122 x 120 x 90, 1-3 heaters, power supply lead max. 10 mm ² , IP66	0X80057
Ex-it-R	Ø 150 x 125 mm, 3 heaters, 1 Pt100 power supply lead, incl. mounting stand, IP 65	0X80070
ELAK-Ex-3.5	122 x 120 x 90 mm, 1 heater, capillary thermostat, IP 66	0X80055
ELAK-5	122 x 120 x 90 mm, polyester, 3 breakouts M25, IP 66	0920013

J Temperature Sensors

ELTF-PTEx.2	Pt100 4 conductor, 3 m PTFE cable	0X70002
ELTF-PTEx.4	2x Pt100 3 conductor, 3 m cold lead	0X70030
ELTF-PT.1	Pt100, 5 x 50 mm PVC 5 m	0650001
ELTF-PT.3	Pt100, 2 conductor, 5 x 50 mm, 3 m PTFE cable	0650003
ELTF-PT.3.1	Pt100, 3 conductor, 5 x 50 mm, 3 m PTFE cable	0650002

Technical Information

Maximum ambient temperature, energized	120 °C
Maximum ambient temperature, de-energized	180 °C
Nominal voltag*	230 V
Bending radius, min.	25 mm
Installation temperature, min.	-60 °C

*Further power inputs on request

Heating circuit lengths on the following conditions

- › 230 V nominal voltage
- › Delayed action circuit breakers (C-characteristic) with 80 % maximum load
- › Maximum 10 % line voltage drop on heating cable bus wire
- › Power connection to one heater end

Type	Nominal output	Dimensions approx. (mm)	Weight approx. (g/m)	Part No.
ELSR-H-10-2-BOT	10 W/m at 10 °C	12.4 x 5.0	120	B0221103
ELSR-H-15-2-BOT	15 W/m at 10 °C	12.4 x 5.0	120	B0221153
ELSR-H-20-2-BOT	20 W/m at 10 °C	12.4 x 5.0	120	B0221203
ELSR-H-30-2-BOT	30 W/m at 10 °C	12.4 x 5.0	120	B0221303
ELSR-H-45-2-BOT	45 W/m at 10 °C	12.4 x 5.0	120	B0221453
ELSR-H-60-2-BOT	60 W/m at 10 °C	12.4 x 5.0	120	B0221603
ELSR-H-75-2-BOT	75 W/m at 10 °C	12.4 x 5.0	120	B0221753

ELSR-H...-2-BOT output

(on insulated metallic pipes according to 62395-1)

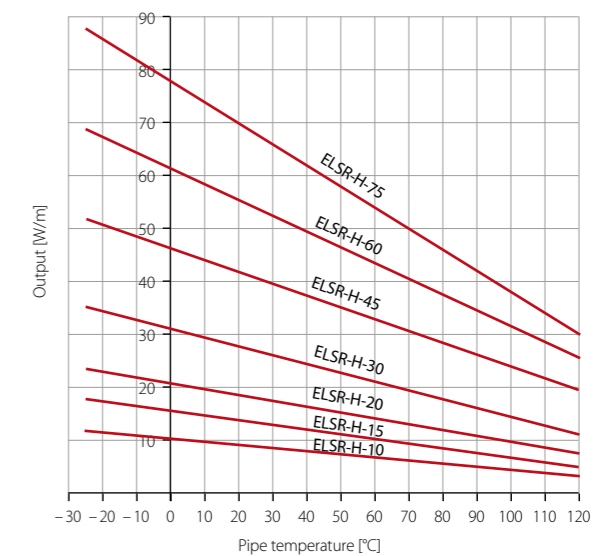

Switch-on temperature (°C)	Nominal cutout value (A)	Heating circuit length (m) for			
		ELSR-H-10-2	ELSR-H-15-2	ELSR-H-20-2	ELSR-H-30-2
10	16	193.0	158.0	122.0	82.0
	20	193.0	158.0	136.0	102.0
	25	193.0	158.0	136.0	111.0
	32	193.0	158.0	136.0	111.0
0	16	189.0	153.0	116.0	77.0
	20	189.0	153.0	132.0	97.0
	25	189.0	153.0	132.0	108.0
	32	189.0	153.0	132.0	108.0
-10	16	184.0	146.0	110.0	73.0
	20	184.0	148.5	129.0	92.0
	25	184.0	148.5	129.0	105.5
	32	184.0	148.5	129.0	105.5
-20	16	180.0	139.0	104.0	70.0
	20	180.0	145.0	125.5	87.0
	25	180.0	145.0	125.5	103.0
	32	180.0	145.0	125.5	103.0
-40	16	173.0	126.0	95.0	64.0
	20	173.0	138.0	119.0	80.0
	25	173.0	138.0	120.0	98.0
	32	173.0	138.0	120.0	98.0

Switch-on temperature (°C)	Nominal cutout value (A)	Heating circuit length (m) for		
		ELSR-H-45-2	ELSR-H-60-2	ELSR-H-75-2
10	16	55.0	41.0	33.0
	20	68.0	51.0	41.5
	25	85.0	64.0	51.5
	32	91.0	79.0	66.0
0	16	52.0	39.0	30.0
	20	65.0	49.0	37.5
	25	81.0	61.0	47.0
	32	88.5	77.0	60.0
-10	16	50.0	37.0	28.5
	20	62.0	46.0	35.5
	25	77.0	58.0	44.5
	32	86.5	70.0	57.0
-20	16	47.0	36.0	26.5
	20	59.0	44.0	33.5
	25	74.0	56.0	41.5
	32	84.5	67.0	53.5
-40	16	43.0	33.0	23.5
	20	54.0	41.0	29.0
	25	68.0	51.0	36.5
	32	81.0	61.0	46.5

At a Glance

Applications

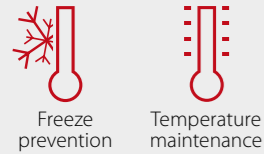

Valves, pumps Silos, vessels, tanks

- › Chemistry and Petrochemistry
- › Oil and Gas Industry
- › Power plants
- › Water and sanitation utilities

Advantages

- › Temperature classification T3*
 - › Five nominal outputs
 - › Moisture proof
 - › Resistant to chemicals
 - › Use in hazardous areas
- *Except for 90 W/m: T2

Design

BOT

Approvals



- › Cable classification
II 2G Ex 60079-30-1 IIC Gb
II 2D Ex 60079-30-1 IIIC Db
- › System classification
II 2G Ex 60079-30-1 eb IIC T2 Gb
II 2D Ex 60079-30-1 tb IIIC T220°C Db
- › Certification
EPS IECEx 18.0019U
EPS IECEx 18.0014X
EPS 18 ATEX 1 028 U
EPS 18 ATEX 1 020 X
- › Temperature class
T2

Type ELSR-SH up to 250 °C

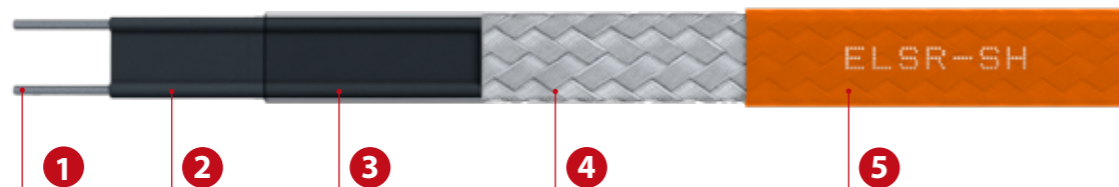

1 Bus wire	Nickel plated copper
2 Self-regulating heating element	
3 Insulation	
4 Protection	Protective braid (Cu, tin plated)
5 Outer jacket	TPE-O, Fluoropolymer

Checklist ELSR-SH

B + C Power Connection & End Termination

ELVB-SREx-25	Power connection, glued, Gland M25 x 1,5, PE	0X81PA1
ELVB-SREx-IT	Power connection, glued, without gland	091AIT1
EL-ECSH-Ex	Silicone termination cap, red, glued, with ex marking	0X81EH2
ELVB-SRAH-25	Power connection, glued, Gland M25 x 1,5, PE	091A040

D Junction Boxes

ELAK-Ex-3.7	122 x 120 x 90, 1-3 heaters, power supply lead max. 10 mm ² , IP66	0X80057
Ex-it-R	∅ 150 x 125 mm, 3 heaters, 1 Pt100 power supply lead, incl. mounting stand, IP 65	0X80070
ELAK-Ex-3.5	122 x 120 x 90 mm, 1 heater, capillary thermostat, IP 66	0X80055
ELAK-5	122 x 120 x 90 mm, polyester, 3 breakouts M25, IP 66	0920013

J Temperature Sensors

ELTF-PTEx.2	Pt100 4 conductor, 3 m PTFE cable	0X70002
ELTF-PTEx.4	2x Pt100 3 conductor, 3 m cold lead	0X70030
ELTF-PT.1	Pt100, 5 x 50 mm PVC 5 m	0650001
ELTF-PT.3	Pt100, 2 conductor, 5 x 50 mm, 3 m PTFE cable	0650003
ELTF-PT.3.1	Pt100, 3 conductor, 5 x 50 mm, 3 m PTFE cable	0650002

Technical Information

Maximum ambient temperature, energized	165 °C
Maximum ambient temperature, de-energized	250 °C
Nominal voltage	230 V
Bending radius, min.	25 mm
Installation temperature, min.	-60 °C

Heating circuit lengths on the following conditions

- › 230 V nominal voltage
- › Delayed action circuit breakers (C-characteristic) with 80 % maximum load
- › Maximum 10 % line voltage drop on heating cable bus wire
- › Power connection to one heater end

Type	Nominal output	Dimensions approx. (mm)	Weight approx. (g/m)	Part No.
ELSR-SH-15-2-BOT	15 W/m at 10 °C	14 x 5,4	146	B0226153
ELSR-SH-35-2-BOT	35 W/m at 10 °C	14 x 5,4	146	B0226353
ELSR-SH-45-2-BOT	45 W/m at 10 °C	14 x 5,4	146	B0226453
ELSR-SH-75-2-BOT	75 W/m at 10 °C	14 x 5,4	146	B0226753
ELSR-SH-90-2-BOT	90 W/m at 10 °C	14 x 5,4	146	B0226903

ELSR-SH-...-2-BOT output

(on insulated metallic pipes according to 62395-1)

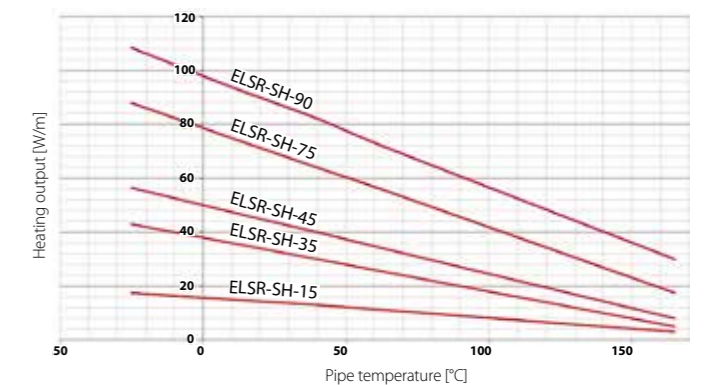

Switch-on temperature (°C)	Nominal cutout value (A)	Heating circuit length (m) for ELSR-SH				
		15-2 BOT	35-2 BOT	45-2 BOT	75-2 BOT	90-2 BOT
10	10	113	50.0	36.25	18.75	17.0
	16	172	80.0	58.0	30.0	27.0
	20	172	99.0	72.5	37.5	34.0
	25	172	107.5	90.625	47.0	42.5
	32	172	107.5	98.0	60.0	54.0
	40	172	107.5	98.0	73.0	68.0
0	10	106	47.0	34.5	17.75	16.0
	16	169	75.0	55.0	28.5	26.0
	20	172	94.0	69.0	35.5	32.0
	25	172	107.5	86.25	44.5	40.0
	32	172	107.5	98.0	57.0	52.0
	40	172	107.5	98.0	71.0	64.0
-10	10	99	44.0	32.5	16.5	15.5
	16	159	71.0	52.0	26.5	25.0
	20	172	89.0	65.0	33.0	31.0
	25	172	107.5	81.25	41.25	38.75
	32	172	107.5	98.0	53.0	50.0
	40	172	107.5	98.0	66.0	62.0

Switch-on temperature (°C)	Nominal cutout value (A)	Heating circuit length (m) for ELSR-SH				
		15-2 BOT	35-2 BOT	45-2 BOT	75-2 BOT	90-2 BOT
-20	10	94	42.0	30.0	15.5	15.0
	16	150	67.0	48.0	25.0	24.0
	20	172	84.0	60.0	31.0	30.0
	25	172	105.0	75.0	38.75	37.5
	32	172	107.5	96.0	50.0	48.0
	40	172	107.5	98.0	62.0	60.0
-30	10	89	40.0	27.5	15.0	14.5
	16	142.5	64.0	44.0	24.0	23.0
	20	172	80.0	55.0	30.0	29.0
	25	172	100.0	68.75	37.5	36.25
	32	172	107.5	88.0	48.0	46.0
	40	172	107.5	98.0	60.0	58.0
-40	10	84	38.0	25.0	14.0	14.0
	16	135	61.0	40.0	22.5	22.0
	20	169	76.0	50.0	28.0	28.0
	25	172	95.0	62.5	35.0	35.0
	32	172	107.5	80.0	45.0	44.0
	40	172	107.5	98.0	56.0	56.0

At a Glance

Applications

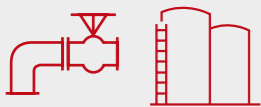
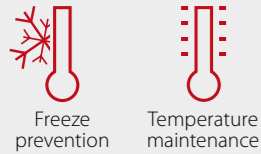

Valves, pumps Silos, vessels, tanks

- › Chemistry and Petrochemistry
- › Oil and Gas Industry
- › Power plants
- › Water and sanitation utilities

Advantages

- › Temperature classification T3*
 - › Five nominal outputs
 - › Moisture proof
 - › Resistant to chemicals
 - › Use in hazardous areas
- *Except for 90 W/m: T2

Design

BOT

Approvals



- › Cable classification
II 2G Ex eb IIC Gb
II 2D Ex tb IIIC Db
- › System classification
II 2G Ex eb IIC T3 Gb
II 2D Ex tb IIIC T200°C Db
- › Certification
EPS 17 ATEX 1 169 X
EPS IECEx 17.0064X
SIRA16ATEX3353
- › Temperature class
T2 to T3

Type ELSR-SHH

up to 250 °C

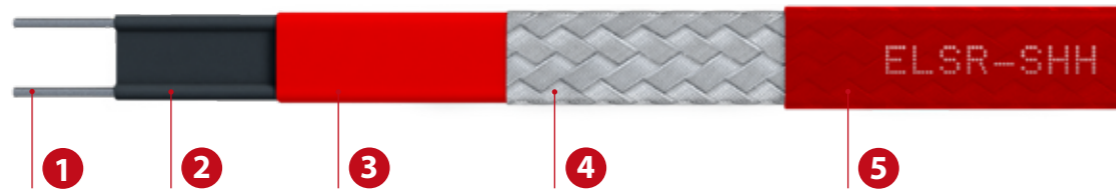

1 Bus wire	Nickel plated copper
2 Self-regulating heating element	
3 Insulation	
4 Protection	Protective braid (Cu, tin plated)
5 Outer jacket	TPE-O, Fluoropolymer

Checklist ELSR-SHH

B + C Power Connection & End Termination

ELVB-SREx-25	Power connection, glued, Gland M25 x 1,5, PE	0X81PA1
EL-ECSh-Ex	Silicone termination cap, red, glued, with ex marking	0X81EH2

D Junction Boxes

ELAK-Ex-3.7	122 x 120 x 90, 1-3 heaters, power supply lead max. 10 mm ² , IP66	0X80057
Ex-it-R	ø 150 x 125 mm, 3 heaters, 1 Pt100 power supply lead, incl. mounting stand, IP 65	0X80070
ELAK-Ex-3.5	122 x 120 x 90 mm, 1 heater, capillary thermostat, IP 66	0X80055
ELAK-5	122 x 120 x 90 mm, polyester, 3 breakouts M25, IP 66	0920013

J Temperature Sensors

ELTF-PTEx.2	Pt100 4 conductor, 3 m PTFE cable	0X70002
ELTF-PTEx.4	2x Pt100 3 conductor, 3 m cold lead	0X70030
ELTF-PT.1	Pt100, 5 x 50 mm PVC 5 m	0650001
ELTF-PT.3	Pt100, 2 conductor, 5 x 50 mm, 3 m PTFE cable	0650003
ELTF-PT.3.1	Pt100, 3 conductor, 5 x 50 mm, 3 m PTFE cable	0650002

Technical Information

Maximum ambient temperature, energized	250 °C
Maximum ambient temperature, de-energized	250 °C
Nominal voltage	230 V
Bending radius, min.	35 mm
Installation temperature, min.	-40 °C

Heating circuit lengths on the following conditions

- › 230 V nominal voltage
- › Delayed action circuit breakers (C-characteristic) with 80 % maximum load
- › Maximum 10 % line voltage drop on heating cable bus wire
- › Power connection to one heater end

ELSR-SHH-...-2-BOT output

(on insulated metallic pipes according to 62395-1)

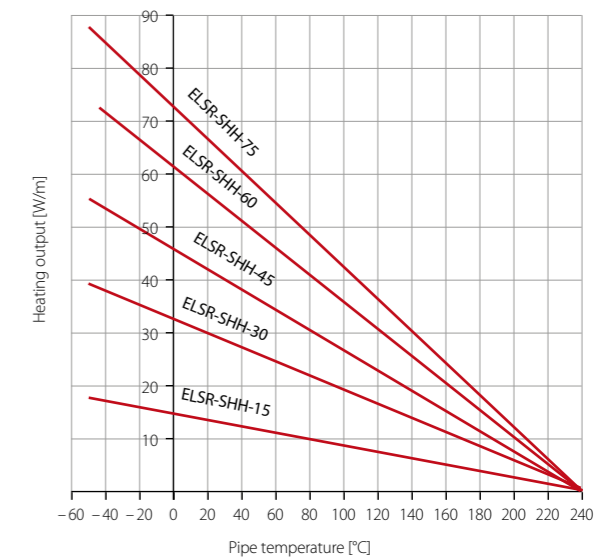

















Switch-on temperature (°C)	Nominal cutout value (A)	Heating circuit length (m) for ELSR-SHH				
		15-2	30-2	45-2	60-2	75-2
10	10	76.0	52.0	38.0	24.0	14.0
	16	122.0	82.0	62.0	38.0	24.0
	20	154.0	102.0	76.0	46.0	28.0
	32	154.0	108.0	88.0	76.0	46.0
0	10	70.0	46.0	32.0	18.0	12.0
	16	112.0	74.0	52.0	30.0	18.0
	20	140.0	92.0	66.0	36.0	22.0
	32	146.0	104.0	84.0	58.0	36.0
-20	10	62.0	40.0	24.0	12.0	8.0
	16	98.5	66.0	38.0	20.0	12.0
	20	122.5	82.0	46.0	26.0	16.0
	32	138.5	98.0	76.0	42.0	24.0
-40	10	52.0	30.0	14.0	8.0	4.0
	16	82.0	50.0	24.0	12.0	8.0
	20	102.0	62.0	28.0	16.0	10.0
	32	126.0	88.0	46.0	24.0	14.0

Type	Nominal output	Dimensions approx. (mm)	Weight approx. (g/m)	Part No.
ELSR-SHH-15-2-BOT	15 W/m at 10 °C	12,1 x 5,4	146	BOHH1153
ELSR-SHH-30-2-BOT	30 W/m at 10 °C	12,1 x 5,4	146	BOHH1303
ELSR-SHH-45-2-BOT	45 W/m at 10 °C	12,1 x 5,4	146	BOHH1453
ELSR-SHH-60-2-BOT	60 W/m at 10 °C	12,1 x 5,4	146	BOHH1603
ELSR-SHH-75-2-BOT	75 W/m at 10 °C	12,1 x 5,4	146	BOHH1753

Accessories







Self-Regulating Trace Heater System

B* – Power Connection Kits

	Type	suitable for ELSR		Description	Ambient temperature	Part No.
	El-Clic P	-N, -LS, -W		Fast connector with integrated cold lead	-40 °C to +100 °C	09ClicP
	El-Clic S	-N, -LS, -W		Fast connector T-splice	-40 °C to +100 °C	09ClicS
	ELVB-SRA-25	-N, -LS, -W, -FHP		Power connection, glued, Gland M25 x 1,5, PE	+100 °C	091A010
	ELVB-SRAH-25	-H		Power connection, glued, Gland M25 x 1,5, PE	+100 °C	091A040
	ELVB-SRAM-25	-M		Power connection, shrink-fit, Gland M25 x 1,5, PE	+100 °C	091A015
	ELVB-SRAR-25	-R		Power connection, shrink-fit, Gland M25 x 1,5, PE	+100 °C	091A020
	ELBV-BF	-M-AF/BF		Power connection/termination set, suitable for drinking water KTW zugelassen	+65 °C	0911022
	ELVB-SRAN-Ex-20	-N, -FHP	●	Power connection, glued, Gland M20, brass	-60 °C to +180 °C	0X81PND
	ELVB-SRAL-Ex-20	-LS	●	Power connection, glued, Gland M20, brass	-60 °C to +180 °C	0X81PLD
	ELVB-SRAH-Ex-20	-H, -SH, -SHH	●	Power connection, glued, Gland M20, brass	-60 °C to +180 °C	0X81PHD
	ELVB-SREx-25	-N, -LS, -H, -FHP	●	Power connection, glued, Gland M25 x 1,5, PE	-25 °C to +70 °C	0X81PA1
	ELVB-SREx-IT	-N, -H	●	Power connection, glued, without gland	-60 °C to +180 °C	091AIT1
	ELVB-SRV-N-L-W	-N, -LS, -W		Connection set, shrink-fit	+65 °C	0911116
	ELVB-SRV-M	-M, -R		Connection set, shrink-fit	+65 °C	0911122
	ELVB-SRV-H	-H		Connection set, shrink-fit	+100 °C	0911117

*Category letters refer to the Checklists on p. 9 and the respective datasheet.



















B* – Power Connection Kits

	Type	suitable for ELSR		Description	Ambient temperature	Part No.
	ELVB-SRV-Ramp	-Ramp		Connection set, shrink-fit	+100 °C	0911124
	Ex-Con-SR	-N, -LS, -H	●	Ex connection sleeve Ø 36 x 210 mm 4J	-32 °C to +200 °C	0X81125
	ELVB-70	-M-AF/BF		Cable gland Ms 3/4", brass, approved for drinking water	+65 °C	0911703
	ELVB-71	-M-AF/BF		Y-connector 32 mm, brass, approved for drinking water	+65 °C	0911704
	M20	-N, -H	●	Ex-d cable gland, brass, fits Y-connector	-60 to +180 °C	2572020003











Accessories

Self-Regulating Trace Heater System

C* – End Termination Kits

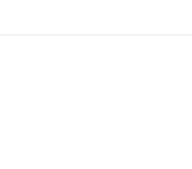
	Type	suitable for ELSR		Description	Ambient temperature	Part No.
	EL-ECSH-ex	-H, -SH, -SHH		Silicone termination cap, red, glued, with ex marking	-45 °C to +85 °C	0X81EH2
	EL-ECL	-LS		Silicone termination cap, glued, transparent	-45 °C to +85 °C	09112L1
	EL-ECL-ex	-LS		Silicone termination cap, glued, transparent with ex marking	-45 °C to +85 °C	0X81EL1
	EL-ECN-ex	-N		Silicone termination cap, glued, transparent with ex marking	-45 °C to +85 °C	0X81EN1
	EL-ECN	-N		Silicone termination cap, glued, transparent	-45 °C to +85 °C	09112N1
	EL-ECM	-M, -R		Silicone termination cap, glued, transparent	-45 °C to +85 °C	09112M1
	EL-ECMF	-M-AF/BF		Silicone termination cap, glued, transparent	-45 °C to +85 °C	09112MF
	EL-ECW	-W		Silicone termination cap, glued, transparent	-45 °C to +85 °C	09112W1
	EL-ECRA	-Ramp		Silicone termination cap, glued, transparent	-45 °C to +85 °C	09112RA
	Ex-It-S	-N, -LS, -H		Heating circuit extension with blind cap, IP65	-60 °C to +55 °C	0X8ITS0
	Ex-It-L	-N, -LS, -H		Heating circuit termination with LED signal light, IP65	-60 °C to +55 °C	0X8ITLG
	ELHKV-E1-1	all		Heating circuit manifold, 1 circuit		0640001
	ELHKV-E1-2	all		Heating circuit manifold, 2 circuits		0640002
	ELHKV-St-3	all		Heating circuit manifold, 3 circuits		0640003
	ELHKV-St-6	all		Heating circuit manifold, 6 circuits		0640006
	ELHKV-St-9	all		Heating circuit manifold, 9 circuits		0640009
	ELHKV-St-12	all		Heating circuit manifold, 12 circuits		0640012

D* – Junction Boxes



	Type	suitable for ELSR		Description	Ambient temperature	Part No.
	ELAK-2	all		104 x 104 x 70 mm, polycarbonate, IP 66, up to 3 heaters, cable gland 1x M25, stamp 7x M20/M25	-40 °C to +70 °C	0920030
	ELAK-5	all		122 x 120 x 90 mm, polyester, IP 66, up to 2 heaters, cable gland 3x M25	-40 °C to +90 °C	0920013
	ELAK-5.1	all		130 x 130 x 75 mm, polycarbonate, IP 66, up to 3 heaters, stamp 9x M20/M25	-35 °C to +80 °C	0920002
	ELAK-5.7	all		122 x 120 x 90 mm, polyester, grey, IP 65, up to 3 heaters, cable gland 1x M25, holes 3x M25	-40 °C to +90 °C	0920014
	ELAK-5.8	all Pt100 temperature sensors		122 x 120 x 90 mm, polyester, grey, IP 65, cable gland 2x M25 1x M16, holes 1x M16	-40 °C to +90 °C	0920015
	ELAK-Ex-3.5	-N, -LS, -H, -SH, -SHH		122 x 120 x 90 mm, 1 heater, capillary thermostat, IP 66, cable gland 1x M25, holes 2x M25	-40 °C to +60 °C	0X80055
	ELAK-Ex-3.7	-N, -LS, -H, -SH, -SHH		122 x 120 x 90, 1-3 heaters, power supply lead max. 10 mm ² , IP66, cable gland 1x M25 2x M12	-40 °C to +60 °C	0X80057
	ELAK-Ex-3.8	all Pt100 temperature sensors		122 x 120 x 90, 1-2 Pt100, max. 2,5 mm ² , IP66, cable gland 1x M25 2x M12	-40 °C to +60 °C	0X80058
	ELAK-Ex-R5	all		∅ 150 x 125 mm, 1 heater, IP 65, cable gland 1x M25, 1x M20, holes 1x M25, 1x M16	-40 °C to +60 °C	0X80075
	ELAK-Ex-R7	-N, -LS, -H, -SH, -SHH		∅ 150 x 125 mm, 1-3 heaters, power supply lead max. 6 mm ² , IP 65, cable gland 1x M25, holes 3x M25	-40 °C to +50 °C	0X80077
	ELAK-Ex-R8	all Pt100 temperature sensors		∅ 150 x 125 mm, 1-2 Pt100, max. 2,5 mm ² , IP 65, cable gland 1x M25 2x M12	-40 °C to +50 °C	0X80078

*Category letters refer to the Checklists on p. 9 and the respective datasheet.





Accessories

Self-Regulating Trace Heater System







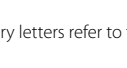







D* – Junction Boxes

	Type	suitable for ELSR	Ex	Description	Ambient temperature	Part No.
	Ex-it-R	-N, -LS, -H, -SH, -SHH	●	∅ 150 x 125 mm, 3 heaters, 1 Pt100 power supply lead, incl. mounting stand, IP 65, cable gland 1x M25	-20 °C to +50 °C	0X80070
	Ex-it-R-T	-N, -LS, -H, -SH, -SHH	●	∅ 150 x 125 mm, 3 heaters, incl. mounting stand, IP 65, cable gland 1x M25	-20 °C to +50 °C	0X80082
	Ex-it-R-Pt	all Pt100 temperature sensors	●	150 x 125 mm, 1 Pt100, 1 sensor cable, incl. mounting stand, IP 65, cable gland 1x M25	-20 °C to +50 °C	0X80092
	ELAK-RS-T	-N, -LS, -W		150 x 125 mm, twin Pt100, 3 heaters incl. mounting stand, IP 65, cable gland 1x M25	-45 °C to +50 °C	0920059
	ELAK-RS	-N, -LS, -H		150 x 125 mm, incl. mounting stand, IP 65, cable gland 1x M25, holes 1x M25 1x M20	-45 °C to +50 °C	0920050

E* – Pipe Mounting Bracket

	Type	suitable for	Ex	Description	Part No.
	ELB-13V1	all	●	Tightening strap, threaded, 11 mm, 30 m, Mat. 1.4301	2723001010
	ELB-13V2	all	●	Turnbuckle 1.4301 (selling unit 10 pieces), Mat. 1.4301	0930042
	ELB-15.04	all	●	Hose clamp, 25 - 40 mm, Mat. 1.4301	2723001025
	ELB-15.06	all	●	Hose clamp, 40 x 60mm, Mat. 1.4301	2723001040
	ELB-15.09	all	●	Hose clamp 40-90 mm (DN 25-65), Mat. 1.4301	2723040090
	ELB-15.11	all	●	Hose clamp, 50 - 110 mm, Mat. 1.4301	2723050110

E* – Pipe Mounting Bracket





	Type	suitable for	Ex	Description	Part No.
	ELB-15.288	all	●	Hose clamp, 60 - 288 mm, Mat. 1.4301	2723060288
	ELB-15.650	all	●	Hose clamp, 60 - 650 mm, Mat. 1.4301	2723060650
	ELB-18	all	●	Assembly and fastening plate for gutters, 290 x 30 x 1,5 mm, Mat. 1.4301	0930040
	ELB-20	all	●	Mounting bracket 90° for downpipes, Mat. 1.4301	0930043
	ELB-21	all	●	Mounting profile for gutters, Mat. 1.4301, 290 mm long	0930044
	ELB-22	all	●	PE mounting profile for trace heaters, spacing 25 mm	0942000
	ELMW-5	ELAK-2	●	Support bracket, 85 x 85 mm, Mat. 1.4301	0941005
	ELMW-9	ELAK-5, ELAK-Ex 3, ELth-1, -BTB, -BSTW	●	Support bracket, 122 x 120 mm, Mat. 1.4301	0941009
	ELMW-11	ELTC-1/4/05, ELAK-5.1	●	Support bracket, 130 x 130 mm, Mat. 1.4301	0941011
	ELMW-Ex-Box	Ex-Box REG / Ex-Box-LIM	●	Support bracket, 185 x 185 mm, Mat. 1.4301	0941072
	ELMW-CT	EL-CT...	●	Support bracket, Mat. 1.4301	0941025
	ELMW-GP1	ELT-GP 1	●	Support bracket 175 x 125 mm, Mat. 1.4301	0941020
	EL-VSB 300	all	●	Variable support bracket, height adjustable from 180 - 300 mm, Mat. 1.4301	0941085
	EL-VSB 400	all	●	Variable support bracket, height adjustable from 280 - 400 mm, Mat. 1.4301	0941086

*Category letters refer to the Checklists on p. 9 and the respective datasheet.





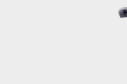

Accessories

Self-Regulating Trace Heater System

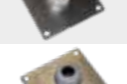
F* – Fasteners and Self-Adhesive Tapes, Foils

	Type	suitable for ELSR	Ex	Description	max. Operating temperature	Part No.
	ELB-02	all	●	Adhesive tape, glass silk 20 m x 12 mm	+140 °C	2486800125
	ELB-02A	all	●	Adhesive tape, glass silk 30 m x 12 mm	+180 °C	2486800126
	ELB-02B	alle	●	Adhesive tape, glass silk 50 m x 12 mm	+180 °C	2486800130
	ELB-06	all	●	Aluminium foil, 50 m x 75 mm, self-adhesive	-40 °C to +140 °C	0942200
	ELB-06D	all	●	Aluminium foil 100 m x 75 mm, self-adhesive	-40 °C to +140 °C	2701900076
	ELB-06C	all	●	Aluminium foil 50 m x 50 mm, reinforcement grid, -40 ... +80 °C	-40 °C to +130 °C	2701900051
	ELB-06E	all	●	Aluminium foil 50 m x 536 mm, self-adhesive	+150 °C	2701900500
	ELB-16.10	all	●	Plastic tightening straps 100 x 2,5 mm, black, UV resistant, selling unit = 100 pcs.	+85 °C	2796000001
	ELB-16.20	all	●	Plastic tightening straps 200 x 3,6 mm, black, UV resistant, selling unit = 100 pcs.	+85 °C	2796000002
	ELB-16.36	all	●	Plastic tightening straps 360 x 4,8 mm, black, UV resistant, selling unit = 100 pcs.	+85 °C	2796000003

G* – Insulation Bushing

	Type	suitable for ELSR	Ex	Description	Part No.
	ELISD-1.12	all temperature sensors	●	3,5 - 7 mm, 70 x 70 mm, 1 x M12 x 1,5	0921011
	ELISD-1.16	all temperature sensors	●	Cover plate, aluminium, 4,5 - 10 mm, 70 x 70 mm, 1 x M16	0921015
	ELISD-1.20	all connections	●	7 - 13 mm, 70 x 70 mm, 1 x M20	0921019
	ELISD-1.25	all connections	●	9 - 17 mm, 70 x 70 mm, 1 x M25	0921023
	ELISD-R1	-N, -LS, -W	●	Cover plate, aluminium, 70 x 70 mm	0921035
	ELISD-R5	-M, -R	●	Insulation bushing	0921101
	ELISD-R4	-H, -SH, -SHH	●	Cover plate, aluminium, 70 x 70 mm	0921047

H* – Warning Signs















	Type	suitable for ELSR	Ex	Description	Part No.
	EL-WS01D	all	●	German "Elektrische Begleitheizung"	2986900002
	EL-WS01E	all	●	English "Electrical Heat Tracing"	2986900012
	EL-WS01F	all	●	French "Traçage Electrique"	2986900032
	EL-WS01R	all	●	Russian "Electrical Heat Tracing"	2986900013
	EL-WS01I	all	●	Italian "Electrical Heat Tracing"	2986900089

*Category letters refer to the Checklists on p. 9 and the respective datasheet.

Accessories



Self-Regulating Trace Heater System

I* – Temperature Controllers





	Type	suitable for ELSR	Ex	Description	Operating temperature	Part No.
	ELTC 05	all		Pt100, 1 relay, 230 V Frostcontrol, +3 °C, 1 load relay	-30 °C to +50 °C	0610002
	ELTC-14	all		Pt100, 2 conductor, 3 conductor; 0 °C to + 390 °C, without Pt100	-25 °C to +55 °C	0620000
	ELTC-14P	all		Pt100, 2 conductor, 3 conductor	-30 °C to +60 °C	0620010
	ELTC-15	all		Pt100, 2 conductor, 3 conductor temperature controller to 999 °C, with ramp function	-25 °C to +55 °C	0621500
	ELTC-21	all		Pt100, 2 conductor, 3 conductor 0 °C bis 400 °C auf Hutschiene 230 VAC	-25 °C to +55 °C	0610093
	ELTC-22	all		Pt100, 2 conductor, 3 conductor 0 °C to 400 °C, rail-mounted 24 VDC	-25 °C to +55 °C	0610094
	ELTC-24P	all		Pt100, 2 conductor, 3 conductor	-30 °C to +60 °C	0620011
	ELTC-41	all		Pt100, 2-2 conductor, 3 conductor 90 to 260 V AC	-25 °C to +55 °C	0620041
	ELTC-42	all		2 x Pt100, 2 conductor, 3 conductor microprocessor, front assembly	-25 °C to +55 °C	0620042
	ELTC-W	-W		Water Comfort System, power controller	-25 °C to +65 °C	0630000
	Ex-Box REG/DIS	all	●	Electronic controller with display, Pt100, 2-Leiter, 3-Leiter	-30 °C bis +60 °C	0X60020
	Ex-Box REG/LED	all	●	Electronic controller with LED, Pt100, 2 conductor, 3 conductor	-30 °C to +60 °C	0X60021
	Ex-Box LIM/LED	all	●	Electronic controller with LED, Pt100, 2 conductor, 3 conductor	-30 °C to +60 °C	0X60023
	Ex-Box LIM/DIS	all	●	Electronic controller with Display Pt100, 2 conductor, 3 conductor	-30 °C to +60 °C	0X60024

*Category letters refer to the Checklists on p. 9 and the respective datasheet.

I* – Temperature Controllers

	Type	suitable for ELSR	Ex	Description	Operating temperature	Part No.
	ISD-1	all		Ice and snow sensor for gutters, including sensor devices	-10 °C to +50 °C	0620623
	ISD-1.1	all		Ice and snow sensor for gutters, including sensor devices	-10 °C to +50 °C	0620624
	EL-CT 50	all	●	Capillary thermostat	-30 °C to +50 °C	0X63050
	EL-CT 30	all	●	Capillary thermostat	-30 °C to +50 °C	0X63030

J* – Temperature Sensors

	Type	suitable for ELSR	Ex	Description	Operating temperature	Part No.
	ELTF-PT.1	all		Pt100, 5 x 50 mm PVC 5 m	-30 °C to +80 °C	0650001
	ELTF-PT.3	all		Pt100, 2 conductor, 5 x 50 mm, 3 m PTFE cable	-50 °C to +250 °C	0650003
	ELTF-PT.3.1	all		Pt100, 3 conductor, 5 x 50 mm, 3 m PTFE cable	-50 °C to +250 °C	0650002
	ELTF-PTEEx.2	all	●	Pt100 4 conductor, 3 m PTFE cable	-45 °C to +235 °C	0X70002
	ELTF-PTEEx.4	all	●	2x Pt100 3 conductor, 3 m cold lead	-45 °C to +235 °C	0X70030
	ISD-STH	all		Temperature- / moisture sensor for gutters	-40 °C to +85 °C	TBC0001

Applications

Self-Regulating Trace Heater System

in Hazardous Areas

A Trace Heater	ELSR-N, -LS, -FHP, -H, -SH, -SHH
B Connection Kit	e. g. Ex-Con-SR (or ELVB...Ex...)
C End Termination Kit	EL-EC...ex
D Junction Box	e. g. Ex-it-R (or ELAK-Ex...)
E Pipe Mounting Fitting	ELMW-..., ELB-...
F Fasteners and Self-adhesive Tapes, Foils	ELB-...
G Insulation Bushing	ELISD-...
H Warning Sign	EL-WS...
I Temperature Controller	e. g. Ex-Box Temperature Controller
J Temperature Sensor	

in Non-Hazardous Areas

A Trace Heater	ELSR-N, -LS, - M, -M-AF/BF, -R, -W, - Ramp, -FHP, -H, -SH, SHH
B Connection Kit	e. g. EI-Clic-P (or ELVB-...)
C End Termination Kit	EL-EC...
D Junction Box	e. g. ELAK-RS
E Pipe Mounting Fitting	ELMW-..., ELB-...
F Fasteners and Self-adhesive Tapes, Foils	ELB-...
G Insulation Bushing	ELISD-...
H Warning Sign	e. g. ELTC-14 Temperature Controller
I Temperature Controller	ELTF-...
J Temperature Sensor	

This is just a schematic overview, not an installation instruction. For detailed information, please contact our engineers.

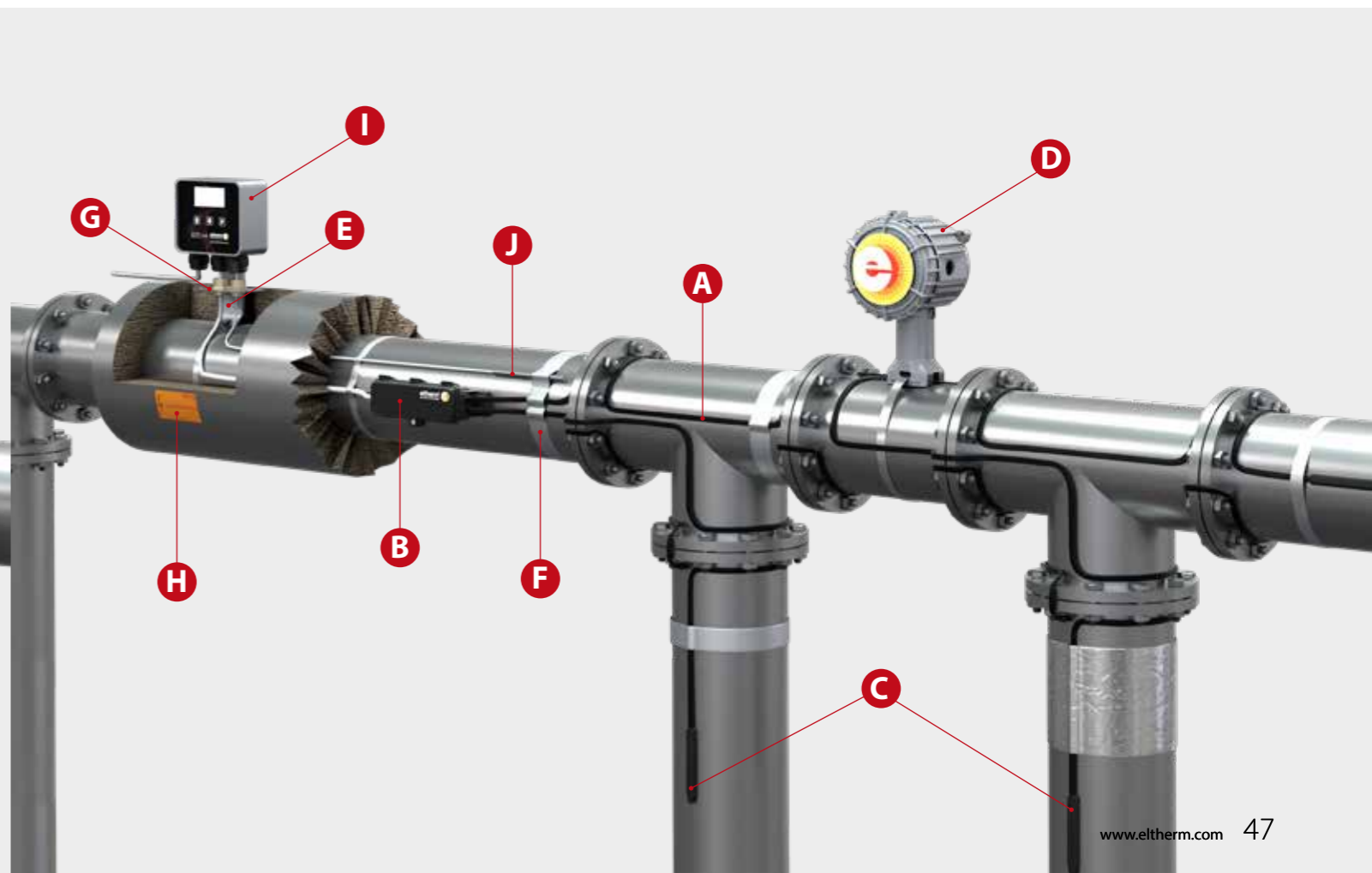
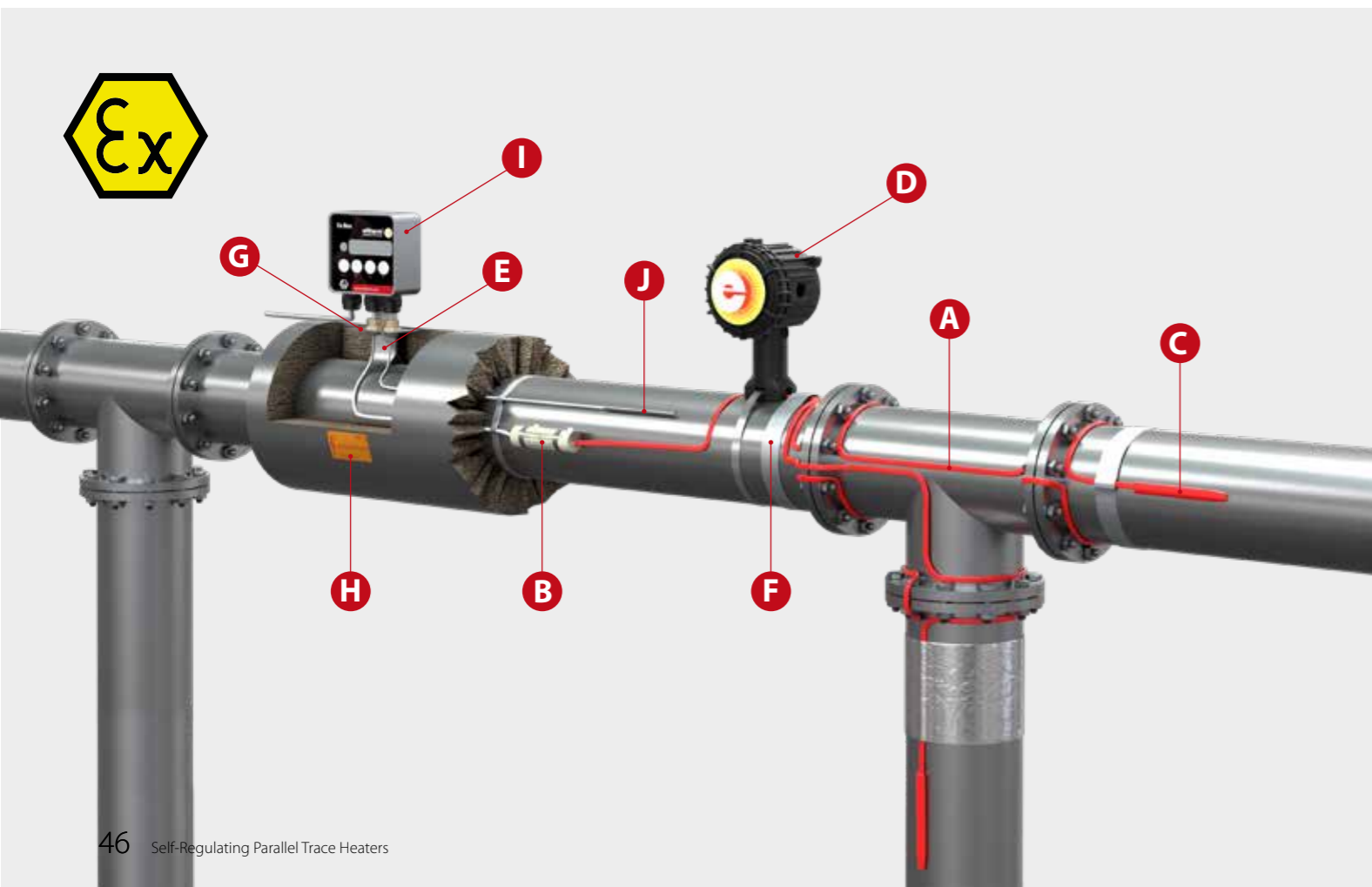

Design Guide

Trace Heater System

Table 1: Design guide freeze prevention +5 °C for self-regulating parallel trace heaters, type series ELSR-N-10...40-2-BO(T)

Pipe size	Inches: DN	1/2 15	3/4 20	1 25	1 1/4 32	1 1/2 40	2 50	2 1/2 65	3 80	4 100	5 125	6 150	7 175	8 200	9 225	10 250	12 300
10	Ambient temperature, min. (°C)	Heating cable Type ELSR-N-10...40-2-BO(T)															
	-15	10	10	20	20	30	30	30	40	2x30	2x30	2x40	2x40	2x40	3x30	3x40	3x40
	-20	10	20	20	20	30	30	40	40	2x30	2x30	2x40	2x40	2x40	3x30	3x40	3x40
20	-15	10	10	10	10	10	20	20	20	30	30	30	40	40	40	2x30	2x30
	-20	10	10	10	10	20	20	20	30	30	30	40	2x30	2x30	2x30	2x30	2x40
	-25	10	10	20	20	30	30	30	30	40	40	2x30	2x30	2x30	2x30	2x40	2x40
30	-15	10	10	10	10	10	10	10	20	20	20	20	30	30	30	40	40
	-20	10	10	10	10	10	20	20	20	20	20	20	30	40	40	40	2x30
	-25	10	10	10	10	20	20	30	30	30	30	40	2x30	2x30	2x30	2x40	2x40
40	-15	10	10	10	10	10	10	10	10	20	20	20	20	20	20	30	30
	-20	10	10	10	10	10	10	10	20	20	20	20	30	30	30	30	40
	-25	10	10	10	10	10	20	20	20	20	20	20	30	30	40	40	2x30
50	-15	10	10	10	10	10	10	10	10	10	20	20	20	20	20	20	30
	-20	10	10	10	10	10	10	10	10	20	20	20	20	30	30	30	30
	-25	10	10	10	10	10	10	20	20	20	20	20	30	30	30	30	40
60	-15	10	10	10	10	10	10	10	10	10	10	20	20	20	20	20	20
	-20	10	10	10	10	10	10	10	10	10	20	20	20	20	20	30	30
	-25	10	10	10	10	10	10	10	20	20	20	20	20	30	30	30	30
80	-15	10	10	10	10	10	10	10	10	10	10	10	20	20	20	20	20
	-20	10	10	10	10	10	10	10	10	10	10	20	20	20	20	20	20
	-25	10	10	10	10	10	10	10	10	20	20	20	20	20	20	20	30
100	-15	10	10	10	10	10	10	10	10	10	10	10	10	10	20	20	20
	-20	10	10	10	10	10	10	10	10	10	10	10	20	20	20	20	20
	-25	10	10	10	10	10	10	10	10	10	10	10	20	20	20	20	20

Basis: Thermal conductivity of the insulation 0.04 W/mK; increased factor of safety 20 %

Table 2: Trace heater additions (m) for

DN	15	20	25	32	40	50	65	80	100	125	150	175	200	225	1250	300
Pair of flanges	0.2	0.2	0.2	0.3	0.3	0.3	0.3	0.3	0.6	0.7	0.8	0.8	0.8	0.8	0.8	0.8
Flanged fitting	0.4	0.4	0.4	0.55	0.55	0.55	0.55	0.55	1.5	2.0	2.4	2.4	2.4	2.4	2.4	2.4
Pumps	1.5	1.5	1.5	2.0	2.0	2.0	2.0	2.0	5.0	5.0	6.0	6.0	6.0	6.0	6.0	6.0

For non-insulated pipe supports: Heating pipe allowance = 4 x support width. Per heating pipe connection in the terminal box / thermostat: Heating pipe allowance approx. 0.5 m. Attention: If there is multiple laying of the heating pipes, the allowances above must be correspondingly multiplied.



Table 3: Heat loss of pipelines in W/m at 10 °K temperature difference

Pipe size	Inches: DN	1/2 15	3/4 20	1 25	1 1/4 32	1 1/2 40	2 50	2 1/2 65	3 80	4 100	5 125	6 150	7 175	8 200	9 225	10 250	12 300
Insulation thickness (mm)	DELTA T																
	10	4.4	5.2	6.1	7.8	8.7	10.5	12.9	14.8	18.6	22.3	26.6	30.3	34.1	37.8	41.9	49.3
20	2.9	3.3	3.7	4.5	5.0	5.9	7.1	8.1	10.0	11.9	14.1	16	17.8	19.7	21.9	25.6	
30	2.2	2.6	2.9	3.4	3.7	4.2	5.2	5.8	7.1	8.4	9.8	11.1	12.4	13.7	15.1	17.6	
40	1.9	2.2	2.5	2.8	3.1	3.5	4.2	4.7	5.7	6.6	7.7	8.7	9.6	10.6	11.7	13.6	
50	1.7	2.0	2.2	2.5	2.7	3.0	3.6	4.0	4.8	5.6	6.4	7.2	8.0	8.8	9.6	11.2	
60	1.6	1.8	2.0	2.2	2.4	2.7	3.2	3.6	4.2	4.9	5.6	6.2	6.9	7.5	8.2	9.5	
80	1.4	1.6	1.7	1.9	2.1	2.3	2.7	3.0	3.4	3.9	4.5	5.0	5.5	6.0	6.5	7.5	
100	1.3	1.4	1.5	1.7	1.8	2.0	2.4	2.6	3.0	3.4	3.8	4.2	4.6	5.1	5.5	6.3	
120	1.2	1.3	1.4	1.6	1.7	1.9	2.2	2.3	2.7	3.0	3.4	3.7	4.1	4.4	4.8	5.4	

Basis: Thermal conductivity of the insulation 0.04 W/mK; increased factor of safety 20 %.
If there are other thermal conductivity figures, the values must be multiplied by a corresponding factor.

Example: Thermal conductivity of the insulation 0.045 W/mK

$$\frac{0,045 \text{ W/mK}}{0,040 \text{ W/mK}} = 1,125$$

Example 1

Task: Frost protection for a DN 100, 25 m long pipeline with 2 pairs of flanges, 1 fitting, 1 pump, 4 supports 0.1 m wide; at an ambient temperature of -25 °C and with a 50 mm thick heat insulation, 230 V.

Design:	from table 1:	Heating cable type ELSR-N-20-BO, single laying	
		Pipeline length 25 m single laying = m	= 25.0 m
	from table 2:	Pair of flanges 2 x 0,6 m	= 1.2 m
		Fitting 1 off x 1.5 m	= 1.5 m
		Pump 1 off x 5.0 m	= 5.0 m
		Pipe support 4 off x 0.1 m x 4	= 1.6 m
		Connection 1 off x 0.5 m	= 0.5 m
			= 34.8 m = order 35 m ELSR-N-20-2-BO

Example 2:

Task: Temperature maintenance for 15 m DN 50 pipeline at 20 °C (caustic soda solution) at minimum ambient temperatures of -10 °C (total DELTA-T of 30 K) and a 40 mm thick heat insulation. Installations: 2 pairs of flanges, 2 fittings, 230V.

If the heating is designed using type ELSR-N self-regulating heating cables, please proceed as follows to select the correct nominal output: Design (from table 3): DELTA-T 10 K heat loss = 3.5 W/m. As total DELTA-T is 30 K (that is to say is 3x higher than DELTA-T in the table), the value found is multiplied by 3: 3.5 W/m x a factor of 3 = 10.5 W/m.

In the temperature output diagram on the ELSR-N datasheet, the intersection of the two lines heating output W/m = 10.5 and temperature +20 °C is between the curves (ELSR-N-10) and (ELSR-N-20). Select the heating cable with the next highest power output (ELSR-N-20). You can now proceed with the heating pipe allowance for the installations as in Example 1.

Questionnaire

for Electrical Heat Tracing Systems



Technical Data, Temperature Maintenance (Compensation of heat losses)

Measurements of the object to be heated	Dimension _____	Ø _____	Length _____
Number of	Fittings _____	Flanges _____	Pipe supports _____
Material of pipe or container:	_____		
Tracing	Horizontal <input type="checkbox"/>	Vertical <input type="checkbox"/>	
Requested maintenance temperature	_____		
Min. ambient temperature	_____		
Max. temperature of the medium <small>e.g. steam-rinsing</small>	_____		
Application	Indoor <input type="checkbox"/>	Outdoor <input type="checkbox"/>	
Does humidity occur	Yes <input type="checkbox"/>	No <input type="checkbox"/>	
Object to be heated	_____		
Insulation material	_____	Thickness _____	Thermal conductivity _____
Supply Voltage	_____	Phases _____	N _____
Hazardous area	Yes <input type="checkbox"/>	No <input type="checkbox"/>	Zone _____ T-Class _____

Additional Data for Increase of Temperature

Charging temperature of medium	_____
Requested final temperature	_____
Requested heating-up period	_____
Quantity / flow-quality	_____ / _____
Spec. heat and density of the medium	_____
Weight of the pipe or container	_____

Temperature Control

Temperature-control or -limitation requested:	Yes <input type="checkbox"/>	No <input type="checkbox"/>	
Capillary-tube controller	Yes <input type="checkbox"/>	No <input type="checkbox"/>	
Electronic controller	Yes <input type="checkbox"/>	No <input type="checkbox"/>	
Temperature sensor	Yes <input type="checkbox"/>	No <input type="checkbox"/>	Actual-value indication: NiCrNi (K) <input type="checkbox"/> FeCuNi (J) <input type="checkbox"/> Pt-100 (RTD) <input type="checkbox"/>
Monitoring of heating circuit	Yes <input type="checkbox"/>	No <input type="checkbox"/>	
Complete control/control cabinet	Yes <input type="checkbox"/>	No <input type="checkbox"/>	

Installation Details

With installation	Yes <input type="checkbox"/>	No <input type="checkbox"/>	Thermal insulation <input type="checkbox"/>	Cable installation <input type="checkbox"/>
Installation on floor level	Yes <input type="checkbox"/>	No <input type="checkbox"/>		
Scaffold requested	Yes <input type="checkbox"/>	No <input type="checkbox"/>	Working height _____	



75.000 km

of trace heaters spanning twice the circumference of the globe in the course of a decade are used in a wide range of industries.

500 bar

and process temperatures up to 450 °C is what eltherm's heated pressure hose systems are built for in industrial applications.

5 Continents 14 Locations

270 Staff Members

work for eltherm all over the world. And for you and your heat tracing challenges.

2.777 Football Fields

is the ground space covered by the solar power plant NOOR in Morocco. Electrical heat tracing performs vital functions there.

Eight Engineering Hubs

provide engineering solutions for turnkey projects and EPC requirements all over the world.

Twenty-three Nations

The eltherm team is multinational. We are natives of a total of 23 nationalities.

550 °C

Molten salts must be kept at this temperature to keep them flowable. They store the sun's energy in concentrated solar power plants.



A contribution to sustainability and climate protection: The eltherm fleet operation was rated carbon-neutral in 2018. To achieve this objective, 143 t CO₂ emissions were compensated by supporting global climate protection projects.

At Your Service eltherm globally

- | | |
|---------------------------|-------------------------|
| Milano/Italy | italia@eltherm.com |
| Rheinau/Switzerland* | schweiz@eltherm.com |
| Shanghai/China | china@eltherm.com |
| Barcelona/Spain | spain@eltherm.com |
| Singapore | asiapacific@eltherm.com |
| Newbury/United Kingdom | uk@eltherm.com |
| Burlington/Canada | canada@eltherm.com |
| Calgary/Canada | canada@eltherm.com |
| Korolev/Russia* | russia@eltherm.com |
| Johannesburg/South Africa | southafrica@eltherm.com |
| Burbach/Germany | deutschland@eltherm.com |
| Casablanca/Morocco | morocco@eltherm.com |
| Santiago de Chile/Chile | chile@eltherm.com |
| Nur-Sultan/Kazakhstan | kazakhstan@eltherm.com |

*Channel Business Partner



Your eltherm Contact



eltherm GmbH
Headquarters

Ernst-Heinkel-Straße 6-10
57299 Burbach, Germany

T: +49 2736 4413-0
F: +49 2736 4413-50
info@eltherm.com

www.eltherm.com

